



US 20070152157A1

(19) **United States**

(12) **Patent Application Publication**
Page

(10) **Pub. No.: US 2007/0152157 A1**
(43) **Pub. Date: Jul. 5, 2007**

(54) **SIMULATION ARENA ENTITY TRACKING SYSTEM**

Publication Classification

(51) **Int. Cl.**
G01J 5/02 (2006.01)
(52) **U.S. Cl.** 250/340

(75) Inventor: **David Wayne Page**, Cocoa, FL (US)

(57) **ABSTRACT**

Correspondence Address:
**STERNE, KESSLER, GOLDSTEIN & FOX
P.L.L.C.**
1100 NEW YORK AVENUE, N.W.
WASHINGTON, DC 20005 (US)

A system and method employing visual tracking devices to locate simulation players and objects within an enclosed space. These visual tracking devices capture a perspective view of the arena and analyze the image at a fixed perception frame rate. Each player and object to be tracked is identified by a light-emitting device called a tracking point source, which is identified in the environment by means of a unique code sent out by the device and received by the visual tracking device. By using multiple tracking point sources, the invention may not only determine positions but also determine the orientation (relationship) between players and objects. A third component in the invention performs frame-to-frame analysis of all visible point sources to determine motion in three dimensions, which is forwarded to the simulation environment where it is used to enmesh the player in the simulation.

(73) Assignee: **Raydon Corporation**, Daytona Beach, FL (US)

(21) Appl. No.: **11/593,066**

(22) Filed: **Nov. 6, 2006**

Related U.S. Application Data

(60) Provisional application No. 60/733,254, filed on Nov. 4, 2005.

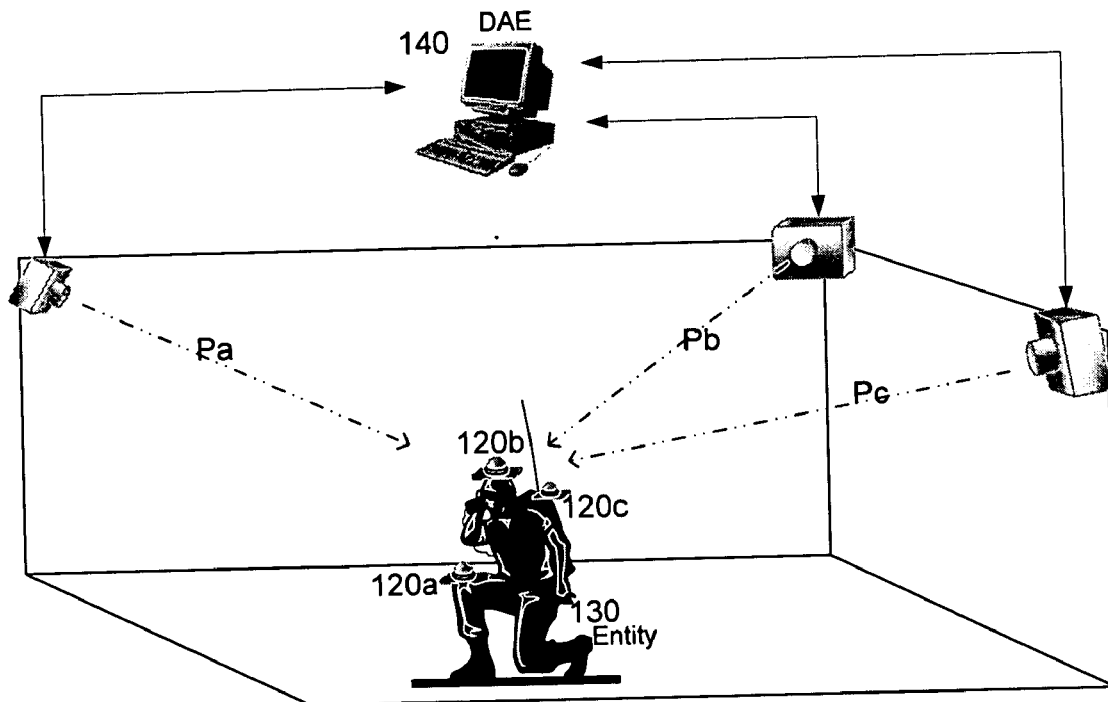

[0030] FIG. 1A and FIG. 1B illustrate an arena 100, which is defined as a bounded region of space which may be either indoors or outdoors, with a plurality energy detection devices 110 which may be video cameras or other visual monitoring devices 110. These visual monitoring devices 110 are mounted in such a way that each one of the visual monitoring devices 110 has a field of view which at least partially overlaps with the field of view of at least one other of the plurality of visual monitoring devices 110.

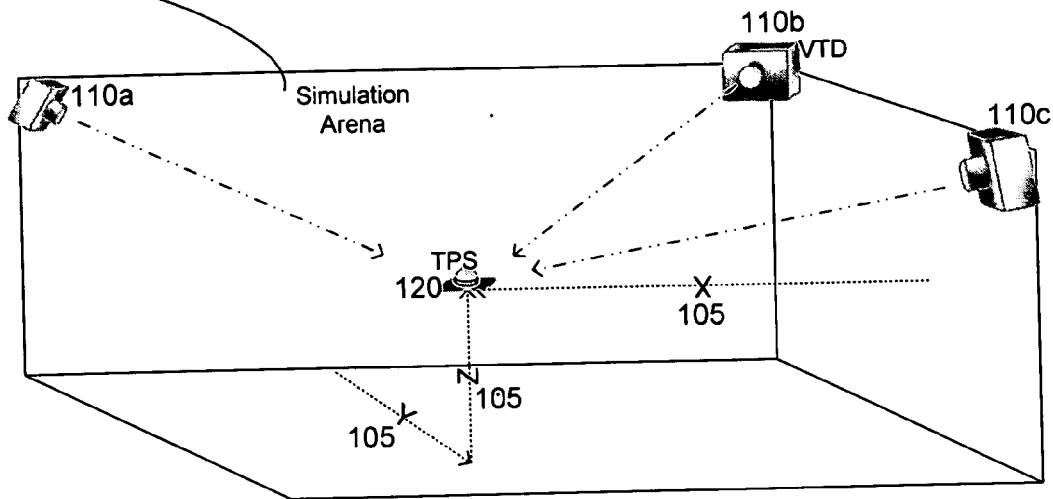

[0033] The arena 100 is generally understood as the bounded volume of space wherein a simulation or gaming event may be conducted... defined by walls or other delimiters or markers, and wherein substantially all or most of the bounded volume of space will be monitored by the plurality of VTDs 110. However, the arena 100 may also be understood to be defined topologically as the set of all points which are visible to two or more VTDs 110.

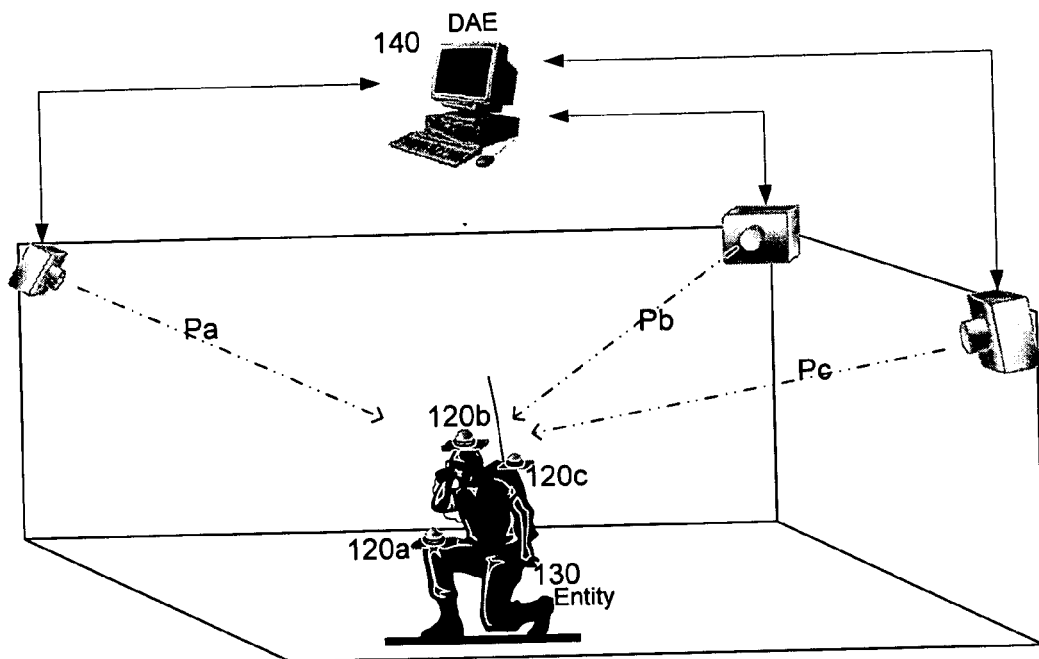

FIG. 1B

[0034] An arena 100 may be created for the purposes of establishing an environment for human training or human event simulation, or for the testing of technologies which may be directly human controlled, remote controlled, or entirely automated, or for other purposes. FIG. 1A also shows how a coordinate system 105 may be imposed upon the arena 100 for the purpose of identifying the location of TPSs 120 within the arena.

200

[0058] In one embodiment of the present invention, it is typically expected that more than one TPS 120 will be used, either because more than one entity 130 is being tracked, or because orientation as well as position of an entity 130 is being tracked, or for a combination of these reasons. In order to track the position and motion of more than one TPS 120, it is necessary that the TPSs 120 attached to the entity or entities 130 can be uniquely identified. This is accomplished by having each TPS 120 emit light according to a modulation pattern which is unique among all the TPSs 120 in the system. This modulation pattern is the "identity message" referred to above.

[0059] The modulation scheme, in turn, has an implementation which relies on the fact that the VTDs 110 capture motion via successive images called "frames", or "perception frames". The VTDs 110 image (i.e., perform image capture of) the arena scene at a periodic rate called the perception rate. Typical video or solid state imaging technology may capture images at a rate on the order of 15 to 30 frames per second.

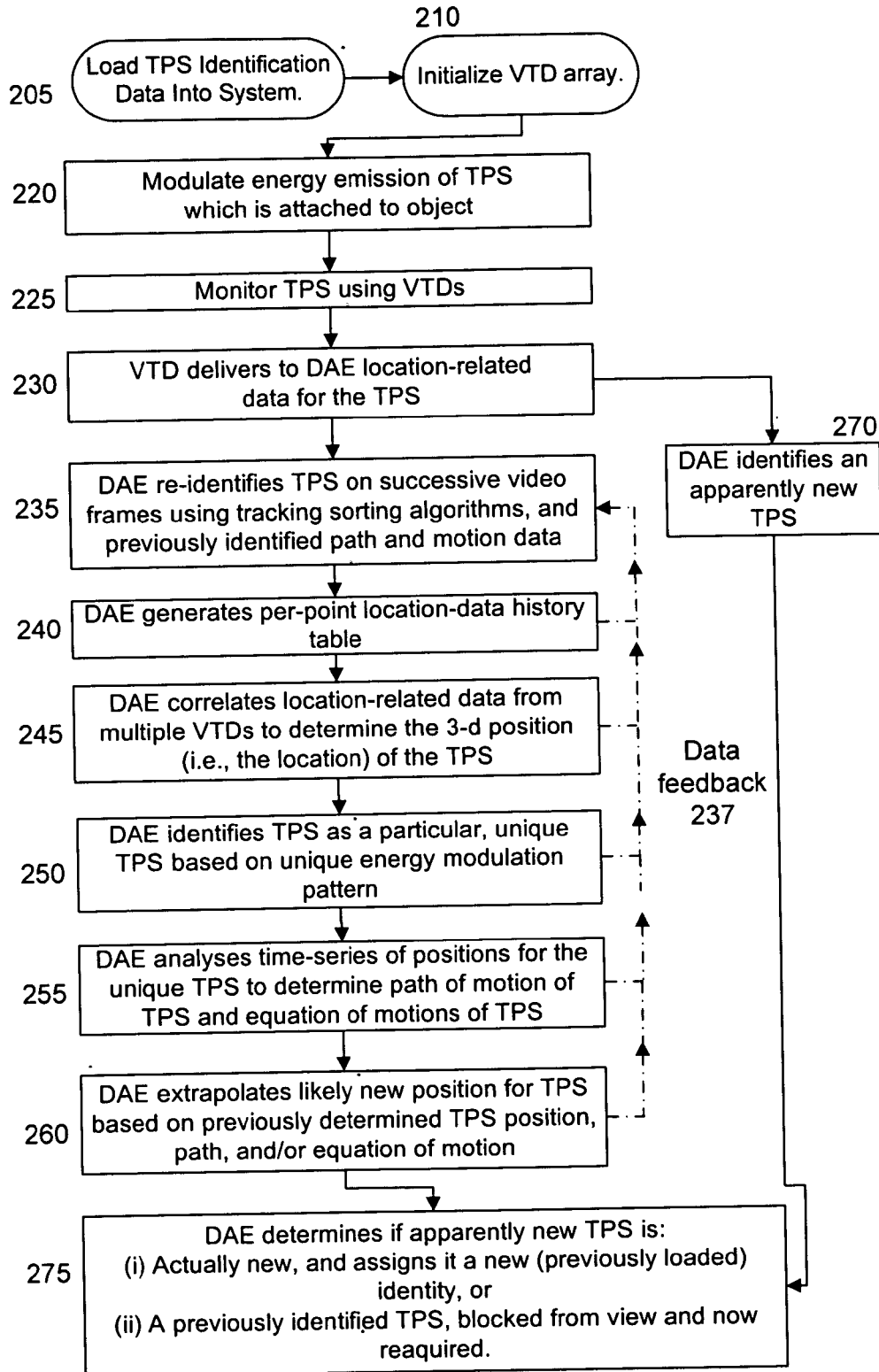

FIG. 2

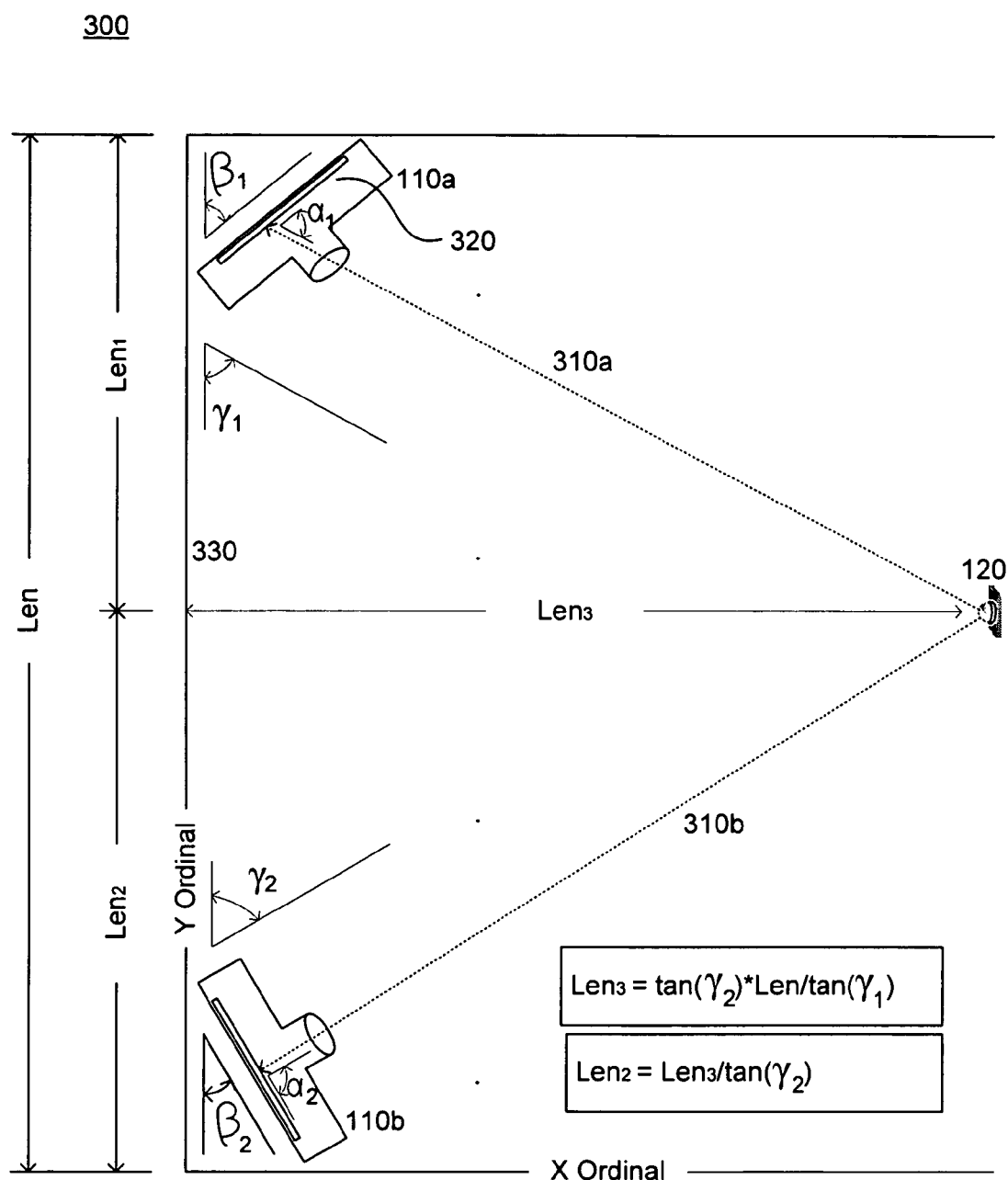

FIG. 3

[0091] In one embodiment of the present invention, the system employs infrared light sources in each TPS 120. The light sources, i.e., the emitters within the TPSs 120, are modulated, as already discussed in general terms above (and as discussed in further detail below) to identify players and entities 130 in the arena 100. Rays of light from the TPSs 120 strike the backplanes 320 of VTDs 110 when the TPSs 120 are within the field of view of the VTDs 110.

[0092] In FIG. 3, .alpha. represents the angle of incidence of a ray of light 310 from a TPS 120 relative to the backplane 320 of a VTD 110, where .alpha. may be a horizontal angle of incidence. (A vertical angle of incidence .lambda. is not illustrated.) .beta. represents the angle between the VTD backplane 320 and the wall 330 of the arena 100. .gamma. is determined from .alpha. and .beta.. For example, in the configuration illustrated, .gamma.=180.degree.-(.alpha.+beta.).

{{Detailed calculations are provided in the full application.}}

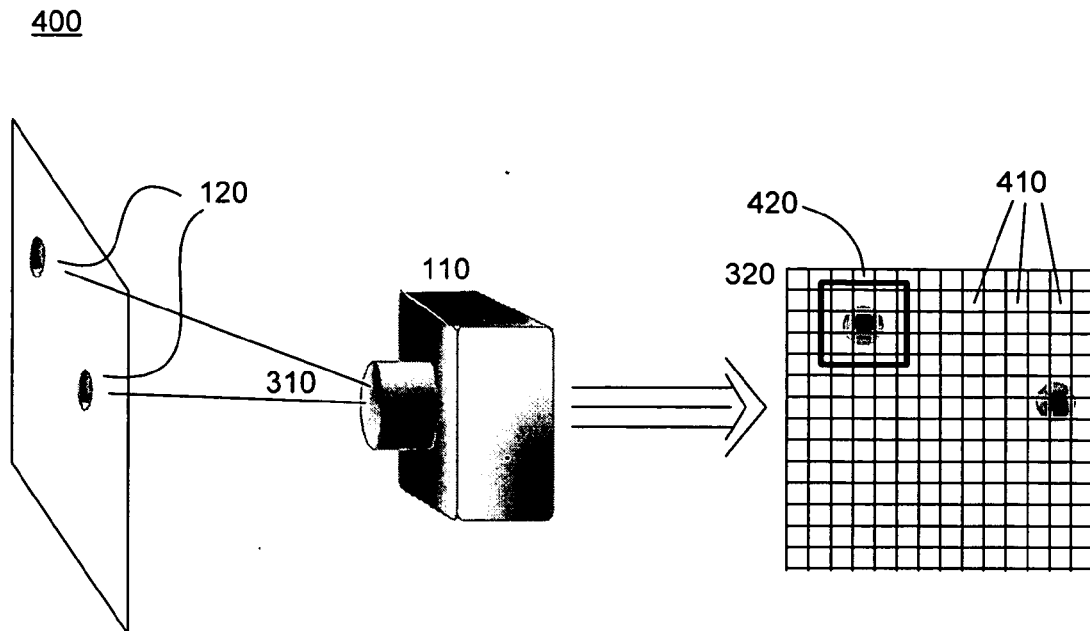

FIG. 4A

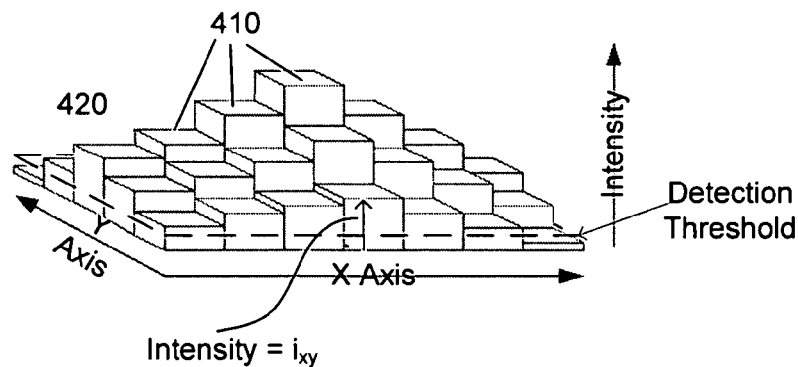

FIG. 4B

[0098] FIG. 4A and FIG. 4B together illustrate an approach 400 for locating a TPS 120 in a VTD 110 field of view, and hence for identifying an angle α , where α represents the angle of incidence of a ray of light 310 from a TPS 120 relative to the backplane 320 of a VTD 110 (as discussed in conjunction with FIG. 3, above).

[0099] FIG. 4A illustrates a VTD 110 observing two TPSs 120, with rays of light 310 from the TPSs 120 striking a lens or other optical element (not shown) of the VTD 110. The lens or other optical elements, possibly in combination with other optical elements (not shown) focuses the rays of light 310 from the TPSs 120 onto backplane 320 (i.e., the imaging element) of VTD 110. The backplane 320 is here represented as a matrix of discrete pixel elements 410 (i.e., sensor cells), which may be physical pixel elements, or which may be logical pixel elements derived from a scanning process or similar process which extracts image information from a continuous light sensitive media of backplane 320.

[0100] FIG. 4B illustrates how different pixel elements or sensor cells 410 in the bounded area of detection 420 may detect different degrees of light intensity. In the figure, the light intensity is exemplified by the height of a pixel element 410. (The "height" is representational only, corresponding to a recorded light intensity, and does not correspond to a physical, structural height of a pixel in a physical backplane or imaging element.) Pixel element 410 may only be considered to have detected light from a TPS 120 if the measure of light intensity from the pixel element 410 exceeds a threshold value.

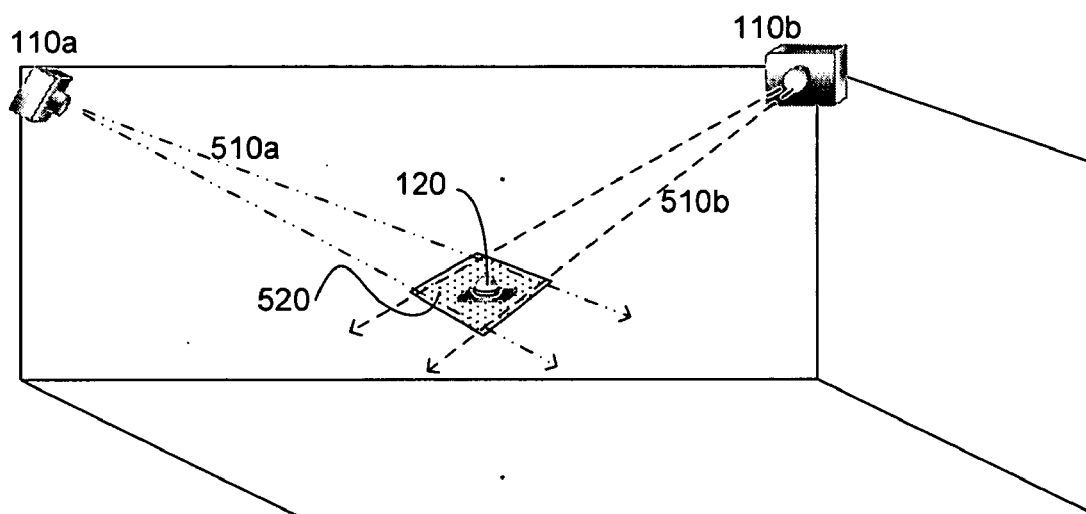

FIG. 5

[0106] In an embodiment of the present invention, it may not be possible for a VTD 110 to determine perfectly precise angles for the location of the TPS 110 centroid, but rather a range of angles which determine a spatial cone in which a TPS be considered to be contained with a high degree of probability. FIG. 5 illustrates a single TPS 120 which is within the field of view of two VTDs 100a and 100b. Pairs of lines 510a and 510b extending from each VTD 110a and 110b respectively indicate an angular range within which each VTD 110 has determined a high probability that the TPS 120 may be found. The intersection of pairs of lines 510a and 510b determines a substantially localized region 520 within which there is a high probability that the TPS 120 may be found.

[0107] For simplicity of viewing only two lines 510 are shown extending from each VTD 110, implying a planar location determination 520; persons skilled in the relevant arts will appreciate that a full determination will involve a cone of high probability extending from each VTD 110, with a corresponding, substantially localized volume of high probability of TPS 120 location determined by the intersection of the cones. If the TPS 110 is in the field of view of more than two VTDs 110, the intersection of more than two cones of probability may result in an improved location determination for the TPS 110.

[0113] Once a TPS 120 centroid is established for more than one frame period, a process of identifying the TPS 120 is begun. To this end a radial bubble sort process 600 is employed to re-identify the TPS 120 on each successive perception frame. FIG. 6 illustrates both the basic components and the steps in this process.

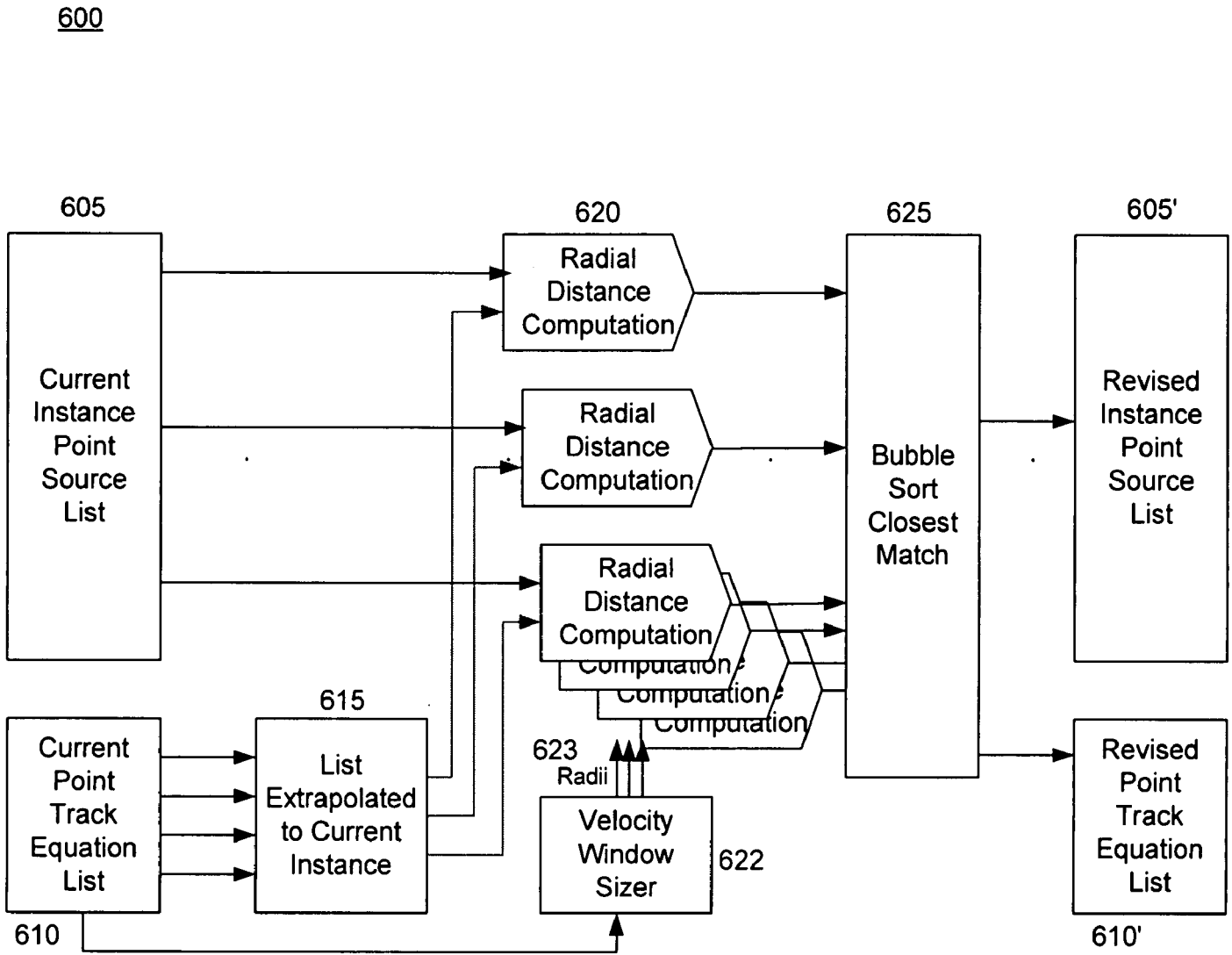

FIG. 6

[0133] FIG. 7A illustrates the synchronous modulation scheme 700 according to one embodiment of the present invention. Periods of time where the TPSs 110 emit light energy are referred to as energy emission events 703. All energy emission events 703 are substantially synchronized with perception frames 702, wherein there exist pairings 705 of perception frames 702 and energy emission events 703. Because the timings of the energy emission events 703 and perception frames 702 are substantially synchronized, each energy emission event 703 may be used to convey a single bit of modulation pattern data, with substantially minimal risk that the VTDs 110 may miss a modulation pattern bit.

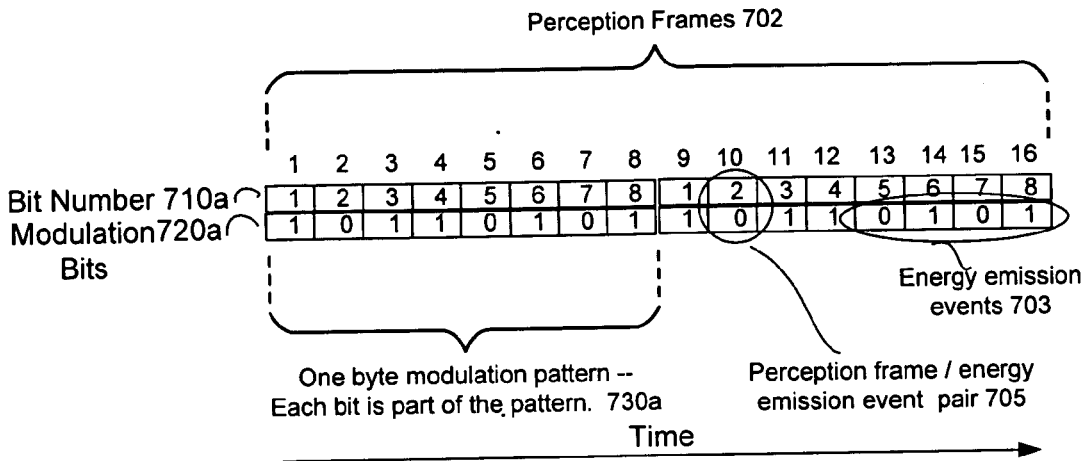

FIG. 7A

750

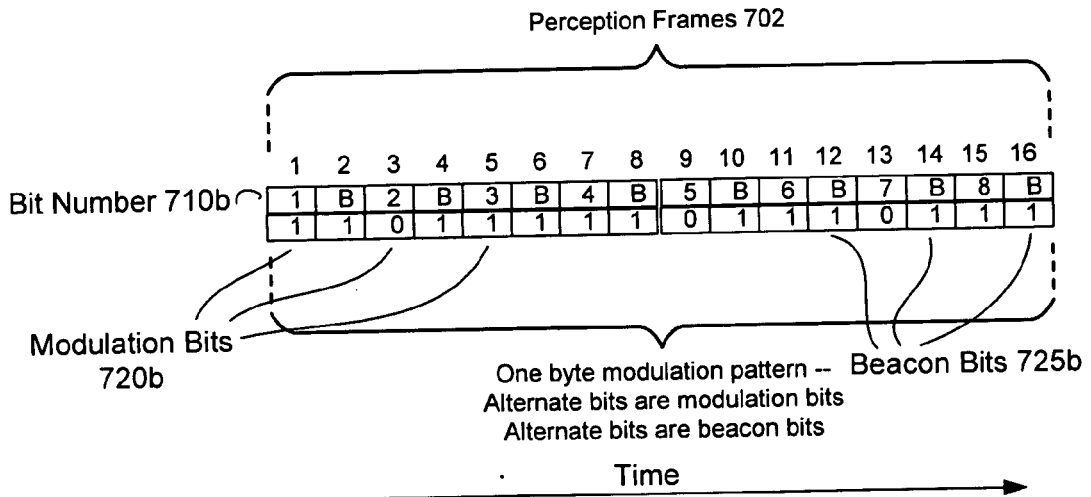

FIG. 7B

[0136] FIG. 7B illustrates a method for synchronous modulation 750 according to an alternative embodiment of the present invention wherein all TPSs may maintain a higher duty cycle, which may result in improved tracking and identification reliability. In this method 750, a subset of perception frames 702 may be associated with modulation bits, wherein the TPS 120 modulates its energy emissions according to a unique modulation pattern, represented by modulation bits 720b; while the remaining perception frames 702 may be associated with beacon bits 725b, which are marked in FIG. 7B with the letter 'B', wherein for each energy emission event corresponding to a beacon bit 725b the TPS 120 always emits energy, i.e., the TPS 120 is always modulated on.

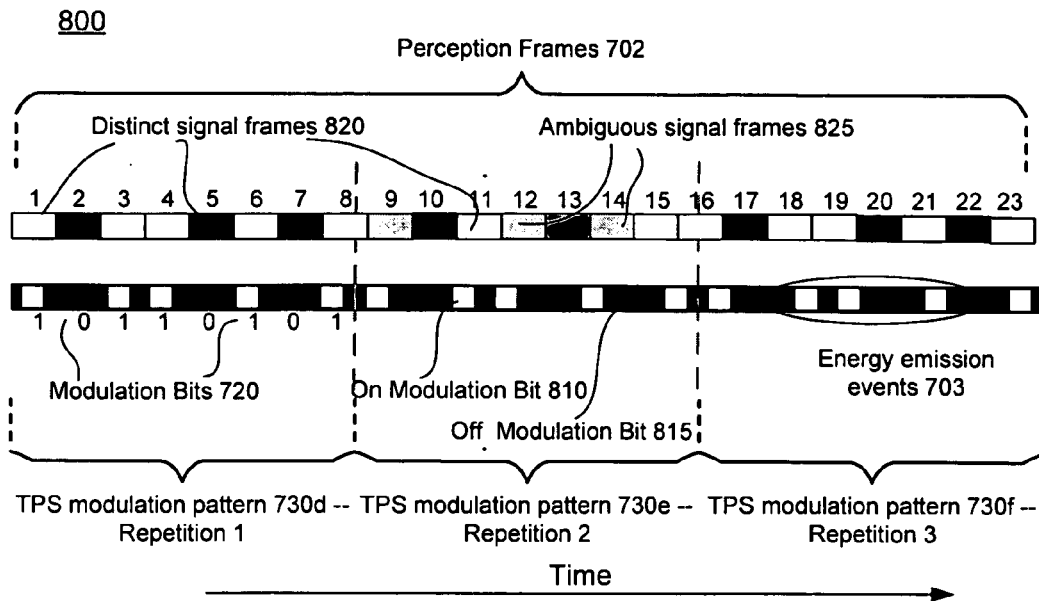

FIG. 8A

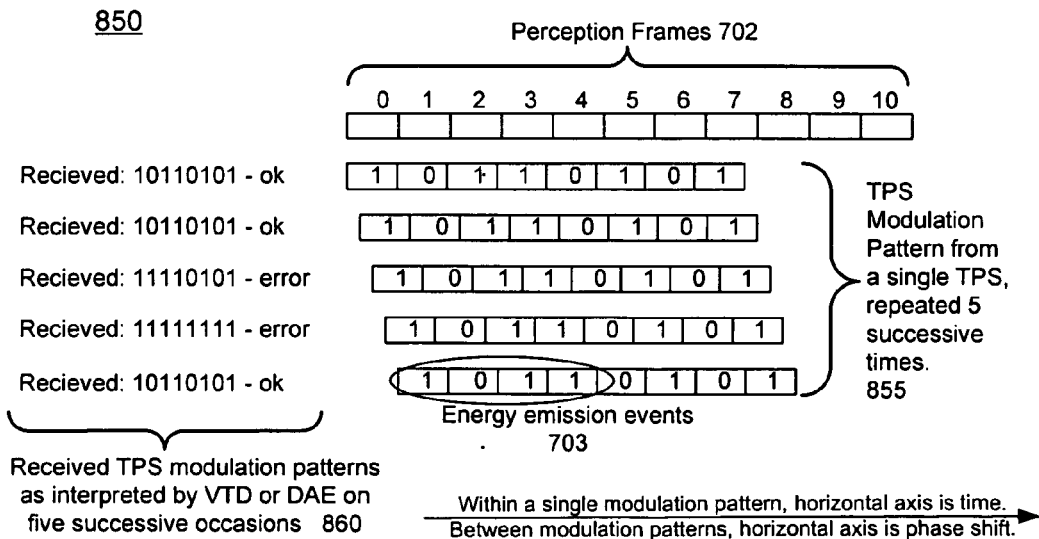

FIG. 8B

[0146] FIG. 8A shows how an exemplary isochronous modulation scheme 800 permits a VTD 110 to determine the modulation pattern of a TPS 120. Note that in this figure, as well as in FIG. 8B discussed below, energy emission events 703, modulation bits 720, and modulation pattern 730 are numbered analogously to the same elements in FIG. 7A and FIG. 7B. This reflects the possibility that, apart from timing and/or synchronization differences, the TPS 120 modulation scheme and TPS 120 energy emission events may be similar or substantially the same for both the synchronous modulation scheme and the isochronous modulation scheme.

[0161] FIG. 9 illustrates various aspects of the present invention, as discussed above, working in combination according to one possible embodiment of the invention. A TPS 120 is being modulated as it moves through the arena 100 space, as illustrated by the alternating data bits 720, which are synonymous with the modulation bits 720 discussed above; and the alternating sync bits 725, which are synonymous with the beacon bits discussed above. (Note the sync bits 725 are always modulated on, i.e., the TPS emits light, while data bits 720 may be modulated on or off.)

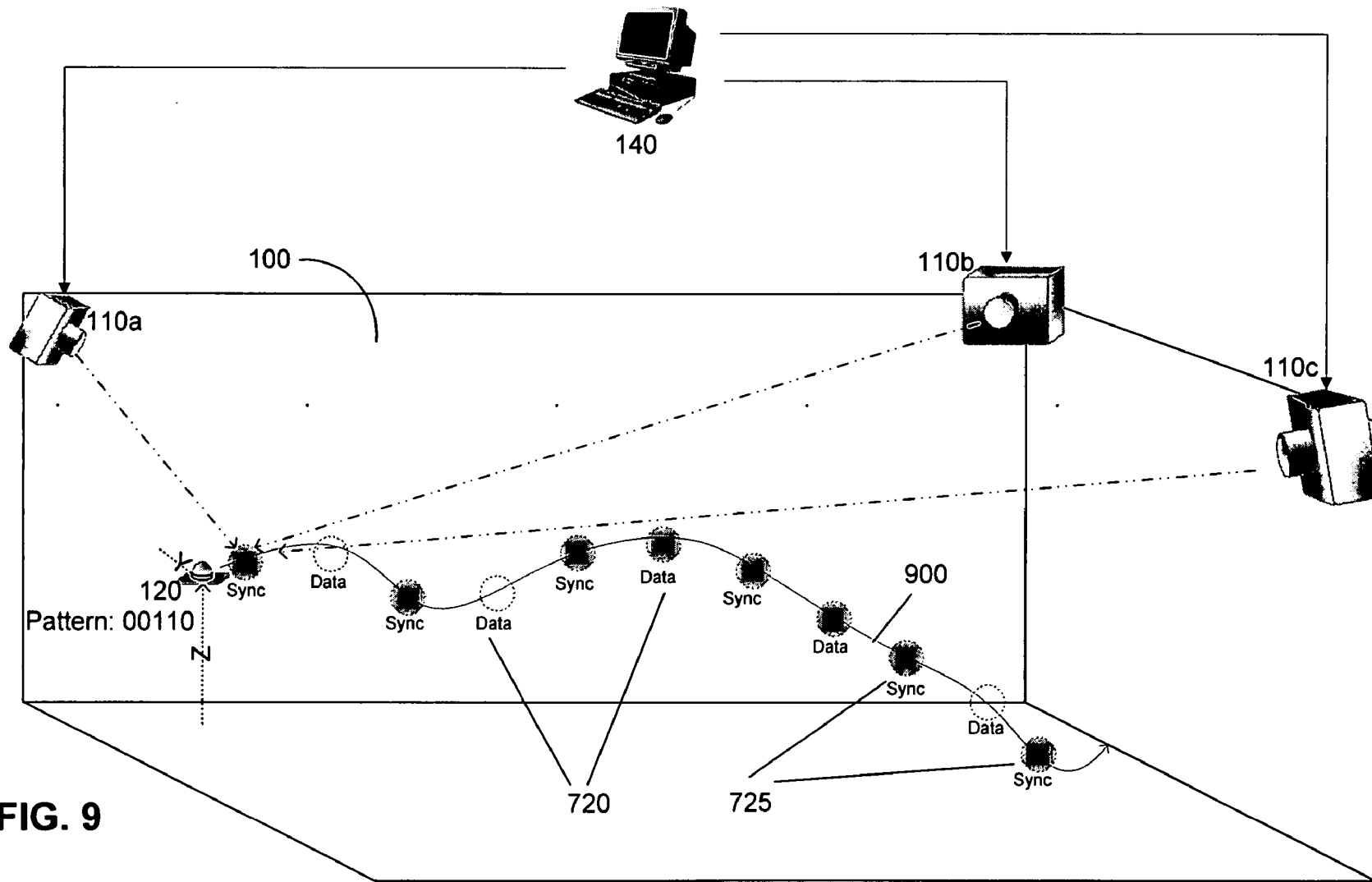

FIG. 9

[0162] DAE 140 receives two-dimensional angular information from multiple VTDs 110, which includes identity information (i.e., TPS 120 modulation data, wherein in the case illustrated the unique TPS modulation pattern 730 is '00110'). DAE 140 uses computed 3-dimensional fixes from various pairs of VTDs 110 to arrive at a bounding space which encloses the actual position of TPS 120. A curve is fit to the centroid of each of these bounded spaces and is assumed to be the current path 900 of TPS 120. The DAE 140 builds motion formulas and exports motion equation coefficients for each TPS path 900 on a frame by frame basis.

SIMULATION ARENA ENTITY TRACKING SYSTEM

CROSS REFERENCE TO RELATED APPLICATION

[0001] This application claims the benefit of U.S. Provisional Application No. 60/733,254, filed on Nov. 4, 2005.

BACKGROUND OF THE INVENTION

[0002] 1. Field of the Invention

[0003] This invention relates to tracking the position and motion of one or more entities in a three-dimensional space as part of a training or simulation environment.

[0004] 2. Background Art

[0005] As understood in this document, a simulation is a physical space in which real people and/or real objects may move, change location, possibly interact with each other, and possibly interact with simulated people and/or simulated objects (whose presence may be enacted via visual projections, audio emissions, or other means) typically in order to train for, prepare for, experience, analyze, or study real-life, potentially real-life, historical, or hypothetical situations, activities, or events. Simulations may be conducted for other purposes as well, such as educational or entertainment purposes, or for analyzing and refining the design and performance of mechanical technologies (such as cars or other transportation vehicles, weapons systems, etc.). The simulation as a whole may also be understood to include any technology which may be necessary to implement the simulation environment or simulation experience.

[0006] A simulation may be conducted in an environment known as a simulation arena (or simply as an arena, for short). Realistic simulations of events play a key role in many fields of human endeavor, from the training of police, rescue, military, and emergency personnel; to the development of improved field technologies for use by such personnel;

[0007] to the analysis of human movement and behavior in such fields as athletics and safety research. Increasingly, modern simulation environments embody simulation arenas which strive for a dynamic, adaptive realism, meaning that the simulation environment can both provide feedback to players in the environment, and can further modify the course of the simulation itself in response to events within the simulation environment. It may also be desirable to collect the maximum possible amount of data about events which occur within the simulation environment.

[0008] For a simulation to be maximally dynamic and adaptive, the technology (which may be a combination of hardware and software) controlling the simulation arena requires information on activity within the simulation environment. An essential component of this information is data on the location and movement of entities-people and objects-within the simulation environment.

[0009] Further, the more specific the location and movement data which may be obtained, the more detailed and refined can be the simulation response. For example, it is desirable to obtain information not only on where a person might be located, but even more specific information on where the person's hands, head, or feet might be at a given

instant. A location granularity on the order of feet or meters is highly desirable, and even more fine-grained location discrimination (such as on the order of inches or centimeters) is desirable as well. It is further desirable to be able to determine the orientation in space of people and objects, as well as their rotational motion.

[0010] A further goal of simulation environment monitoring is to be able to distinguish between specific entities within the simulation environment, so that each real person and each real object has a unique identity within the environment, and so that the location, movement, and simulation history of each real person and real object may be tracked effectively. Yet a further goal is to provide person/object location tracking in real-time, so that adaptive responses may be provided in real-time as well.

[0011] However, obtaining detailed information on the location and movement of entities in a simulation environment offers significant technical challenges. One possible means of tracking is to simply monitor the environment via a video camera or multiple video cameras, and use computer-based analysis to track the movements of people and objects. However, a typical simulation may involve dozens or possibly hundreds, even thousands of real people and real objects, all of which must be tracked. The real-time automated analysis of complex visual data is an art-form still in its infancy; achieving a detailed delineation and tracking of the location and movement of dozens or hundreds of entities using only computer analysis of video images may not be cost-effective in terms of the amount of computing power required. Moreover, using this technology to achieve acceptable entity-identification reliability, acceptable location-determination reliability, real-time processing, or a combination of the above, may be difficult as well.

[0012] A means to achieve the desired goal is to physically attach, to the simulation participants (i.e., to the real persons and real objects within the simulation arena), some kind of signal emitting or signal receiving technology which can assist in the identification and location monitoring of the participants. (Simulation participants may also be known as "entities".)

[0013] As one example of this approach, a global positioning system (GPS) monitor may be attached to simulation participants, enabling a determination of their location via the GPS system. However, GPS monitors may be bulky and expensive, and also may not provide the desired degree of location resolution. Another approach may be to attach radio-frequency (RF) emitters to the simulation participants, wherein nearby RF monitoring devices may detect the RF emissions and so do location determinations. However, due to the long wavelengths of RF emissions, and also due to other factors related to RF behavior in small, object-filled environments, obtaining location data by this means may not be reliable either. Similarly, other means of entity location determination, such as audio signaling, pose significant technical challenges as well.

[0014] Given the foregoing, what is needed is a method and system for determining the position of entities in a simulation environment, wherein the position and movement of each unique entity can be uniquely tracked. What is further needed is a method and system for accomplishing this goal which provides a high degree of both spatial and time resolution, so that detailed location and movement

tracking of each entity may be accomplished. What is further needed is a method and system of entity location determination and entity movement tracking in a simulation environment which is cost-effective, and which is unobtrusive in terms of its impact on entities within the simulation environment.

SUMMARY OF THE INVENTION

[0015] This invention uses energy-emitting tracking point sources (TPSs) to identify the location and motion of entities (persons and objects) within a simulation environment, where the TPSs typically emit light in the infrared ranges. By modulating the TPSs in a distinguishing manner, each TPS may be uniquely identified. The TPSs are viewed by each of a plurality of visual tracking devices (VTDs), wherein the VTDs record activity in a sequential series of short periodic time intervals known as perception frames. By correlating location-related data from multiple VTDs, it is possible to determine the three-dimensional location of the uniquely identified TPSs. Further processing then determines a path and an equation of motion of each TPS.

[0016] By performing this process using hundreds of TPSs, the motion and orientation of entities in an arena may be discerned for each perception frame. The motion and orientation of each TPS in an arena may then be used for any of a variety of purposes including, for example and without limitation, updating head mounted display views, determining weapon aim-points, or determining locations of physical obstacles in a virtual world. This system may also be employed, for example, for tracking objects or players in sports events, analyzing dance choreography, and facilitating analysis of other multi-body three-dimensional motion problems.

BRIEF DESCRIPTION OF THE DRAWINGS/FIGURES

[0017] The features and advantages of the present invention will become more apparent from the detailed description set forth below when taken in conjunction with the drawings in which like reference numbers indicate identical or functionally similar elements.

[0018] Additionally, the left-most digit of a reference number identifies the drawing in which the reference number first appears (e.g., a reference number '310' indicates that the element so numbered first appears in FIG. 3). Additionally, elements which have the same reference number, followed by a different letter of the alphabet or other distinctive marking (e.g., an apostrophe), indicate elements which are the same in structure, operation, or form but may be identified as being in different locations in space or recurring at different points in time (e.g., reference numbers '110a' and '110b' may indicate two different energy detection devices which are functionally the same, but are located at different points in a simulation arena).

[0019] FIG. 1A and FIG. 1B illustrate an arena where a simulation event takes place, and where energy-emitting tracking point sources (TPSs) attached to entities (people or objects) are used to monitor entity motion in the arena.

[0020] FIG. 2 is a flow chart showing the overall process of determining the identity, location and movement of an entity in an arena according to one embodiment of the present invention.

[0021] FIG. 3 illustrates a method for the computation of the location of a TPS in the arena, where the TPS is in the field of view of a visual tracking device (VTD) which is mounted in the arena to monitor TPSs, according to one embodiment of the present invention.

[0022] FIG. 4A and FIG. 4B together illustrate a method for locating a TPS in a VTD field of view, and hence for identifying an angle of incidence of a ray of light from a TPS relative to the backplane of the VTD, according to one embodiment of the present invention.

[0023] FIG. 5 illustrates how two VTDs together may determine a substantially localized region in space in which a TPS may be located, according to one embodiment of the present invention.

[0024] FIG. 6 illustrates a process for tracking the location of a moving TPS over time, according to one embodiment of the present invention.

[0025] FIG. 7A and FIG. 7B illustrate two different embodiments of a synchronous energy modulation scheme which may be used to uniquely identify a TPS.

[0026] FIG. 8A and 8B illustrate two different embodiments of an isochronous energy modulation scheme which may be used to uniquely identify a TPS.

[0027] FIG. 9 illustrates how various aspects of the present invention, such as location identification, path tracking, and object identification, may work in combination with each other in one possible embodiment of the invention.

[0028] Further embodiments, features, and advantages of the present invention, as well as the operation of the various embodiments of the present invention, are described below with reference to the accompanying figures.

DETAILED DESCRIPTION OF THE INVENTION

[0029] An embodiment of the present invention is now described with reference to the figures. While specific configurations and arrangements are discussed, it should be understood that this is done for illustrative purposes only. A person skilled in the relevant art(s) will recognize that other configurations and arrangements can be used without departing from the spirit and scope of the invention. It will be apparent to a person skilled in the relevant art that this invention can also be employed in a variety of other systems and applications.

Overview

[0030] FIG. 1A and FIG. 1B illustrate an arena 100, which is defined as a bounded region of space which may be either indoors or outdoors, with a plurality energy detection devices 110 which may be video cameras or other visual monitoring devices 110. These visual monitoring devices 110 are mounted in such a way that each one of the visual monitoring devices 110 has a field of view which at least partially overlaps with the field of view of at least one other of the plurality of visual monitoring devices 110. These visual monitoring devices 110 are referred to, in the present context, as visual tracking devices 110 (VTDs), and may be mounted in the periphery, or the interior, or both the periphery and interior, of a bounded volume of space to be monitored. FIG. 1 illustrates an exemplary embodiment

various pairs of VTDs 110 to arrive at a bounding space which encloses the actual position of TPS 120. A curve is fit to the centroid of each of these bounded spaces and is assumed to be the current path 900 of TPS 120. The DAE 140 builds motion formulas and exports motion equation coefficients for each TPS path 900 on a frame by frame basis.

Summary

[0163] While some embodiments of the present invention have been described above, it should be understood that it has been presented by way of examples only and not meant to limit the invention. It will be understood by those skilled in the art that various changes in form and detail may be made therein without departing from the spirit and scope of the invention as defined in the appended claims. Thus, the breadth and scope of the present invention should not be limited by the above-described exemplary embodiments, but should be defined only in accordance with the following claims and their equivalents.

What is claimed is:

1. A method for identifying the location of an entity in a three-dimensional space comprising:

- (a) modulating an energy emission from a source of energy emission, wherein the source of energy emission is attached to the entity, and wherein the energy emission from the source is modulated according to an energy modulation pattern;
- (b) monitoring the source using an energy detection device;
- (c) obtaining from the energy detection device at least one of the energy modulation pattern of the source or an identification of the source determined by the energy detection device based on the energy modulation pattern;
- (d) obtaining from the energy detection device location-related data for the source; and
- (e) analyzing the location-related data to determine the location of the source.

2. The method of claim 1, wherein the source modulates its energy emission according to an energy modulation pattern unique to the source.

3. The method of claim 1, wherein the energy emission from the source is an infrared (IR) energy emission.

4. The method of claim 1, wherein the energy detection device detects energy from the source during each of a series of perception frames that occur at a periodic perception frame rate.

5. The method of claim 4, further comprising determining an angular movement of the entity by determining over a plurality of perception frames the locations of a plurality of sources of energy emission which are attached to the entity.

6. The method of claim 4, further comprising modulating the energy from the source according to a synchronous modulation scheme, said synchronous modulation scheme comprising:

- (i) synchronizing the energy emission of the source with the perception frame of the energy detection device;
 - wherein a single period of time wherein energy may be emitted or energy may not be emitted from the

source to signal a single bit in the energy emission pattern is an energy emission event; and

wherein the duration in time of an energy emission event is substantially the same as the duration in time of a perception frame;

- (ii) modulating the energy emission from the source on or off during a single energy emission event;

wherein the source is modulated on by at least one of emitting energy for greater than an on-modulation threshold period of time during the energy emission event or emitting energy at greater than an on-modulation threshold level of energy during the energy emission event; and

wherein the source is modulated off by at least one of emitting energy for less than an off-modulation threshold period of time throughout the duration of the energy emission event or emitting energy at less than an off-modulation threshold level of energy throughout the duration of the energy emission event;

- (iii) modulating the energy emission from the source on or off over a plurality of energy emission events;

wherein the number of energy emission events in the plurality of energy emission events equals a number of bits in the energy modulation pattern; and

wherein the modulated energy emission over the plurality of energy emission events conforms to the energy modulation pattern.

7. The method of claim 6, wherein step (i) further comprises synchronizing the energy emission of the source with the perception frame of the energy detection device by a synchronization signal, wherein the synchronization signal comprises at least one of an infrared signal, a magnetic signal, a radio frequency signal, a laser signal, an electromagnetic signal, or an audio signal.

8. The method of claim 6, further comprising:

- (iv) selecting a first subset of the energy emission events as beacon events,

wherein the unique source is always modulated on during a beacon event;

- (v) selecting the energy emission events which are not part of the first subset as a second subset of signal-modulation events; and

- (vi) modulating the energy emission from the unique source according to the modulation pattern over a plurality of signal-modulation events.

9. The method of claim 4, further comprising modulating the energy from the source according to an isochronous modulation scheme, said isochronous modulation scheme comprising:

- (i) establishing a fixed periodic rate of energy emission activity for the unique source, wherein the fixed periodic rate of energy emission activity is substantially close to the perception frame rate but is not the same as the perception frame rate;

wherein each period of energy emission activity from the unique source is an energy emission event, wherein each energy emission event persists for a

period of time which is substantially close to but not that same as the duration in time of the perception frame; and

wherein an energy emission event may be substantially in phase with a perception frame, and wherein another energy emission event may be substantially out of phase with an immediately preceding perception frame and a perception frame which immediately follows the immediately preceding perception frame;

- (ii) modulating a consecutive series of energy emission events of the unique source on or off over a plurality of energy emissions events;

wherein the source is modulated on by at least one of emitting energy for greater than an on-modulation threshold period of time during an energy emission event or emitting energy at greater than an on-modulation threshold level of energy during an energy emission event;

wherein the source is modulated off by at least one of emitting energy for less than an off-modulation threshold period of time throughout the duration of an energy emission event or emitting energy at less than an off-modulation threshold level of energy throughout the duration of an energy emission event;

wherein the number of energy emission events in the plurality of energy emission events equals a number of bits in the energy emission pattern; and

wherein the modulated energy emission over the plurality of energy emission events conforms to the energy modulation pattern; and

- (iii) determining when a received modulated energy emission from the source which is received by the energy detection device conforms to the energy modulation pattern of the source.

10. The method of claim 9, wherein step (iii) comprises at least one of determining that the energy modulation pattern detected from the source of energy modulation conforms to a previously detected energy modulation pattern of the source or determining that the energy modulation pattern received from the source of energy modulation is an unambiguous energy modulation pattern.

11. The method of claim 4, further comprising determining at least one of a path of movement of the source or an equation of motion of the source based on the location of the source during a plurality of perception frames.

12. The method of claim 11, further comprising extrapolating an extrapolated current position of the source based on at least one of a past location of the source, the path of movement of the source, or the equation of motion of the source.

13. The method of claim 12, further comprising determining that a newly identified source is the same as a previously identified source based on the location of the newly identified source and the extrapolated current position of the source.

14. The method of claim 13, further comprising distinguishing a plurality of newly identified sources of energy emission by using a closest match algorithm to determine which newly identified source is associated with the extrapolated current position of the source.

15. The method of claim 1, wherein the location-related data comprises at least one of an angular displacement or an energy intensity for the source detected by the energy detection device.

16. The method of claim 1, further comprising monitoring the source using a plurality of energy detection devices.

17. The method of claim 16, wherein each energy detection device detects energy from the source within a field of view of the energy detection device, and wherein at least two of the energy detection devices have an overlapping field of view.

18. The method of claim 17, wherein the location-related data obtained from each energy detection device comprises at least one of a respective angular displacement or a respective energy intensity for the source within the field of view of each respective energy detection device.

19. The method of claim 18, wherein a known location in relation to the three-dimensional space for each of the plurality of energy detection devices is combined with at least one of the angular displacement for the source or the energy intensity for the source within the field of view of each of the plurality of energy detection devices to determine the location of the source during a perception frame.

20. The method of claim 19, further comprising:

determining a plurality of volumes in a space, wherein each volume in the space is determined by at least one of a respective angular displacement of the source or a respective energy intensity for the source within the field of view of a plurality of respective energy detection devices; and

determining the location of the source during the perception frame as the intersection of the plurality of volumes.

21. The method of claim 1, further comprising determining at least one of an angular position of the entity or an orientation of the entity by determining the locations of a plurality of sources of energy emission which are attached to the entity.

22. A system for identifying the location of an entity in a three-dimensional space comprising:

a source of energy emission, wherein the source is attached to the entity, and wherein the source modulates an energy emission according to a unique energy modulation pattern, wherein the source is a unique source;

an energy detection device which monitors the unique source, wherein the energy detection device obtains location-related data for the unique source; and

a means for analyzing the location-related data obtained from the energy detection device, wherein said means determines the location of the unique source, and wherein said means for analyzing location-related data is a data analysis engine.

23. The system of claim 22, wherein the energy detection device detects energy from the unique source during a perception frame, and wherein a first perception frame is followed by a second perception frame at a periodic perception frame rate.

24. The system of claim 23, wherein the unique source modulates the energy emission on and off according to the unique energy modulation pattern at a rate which is substantially synchronized with the perception frame rate of the energy detection device, and wherein over a plurality of

perception frames the energy detection device receives the unique energy modulation pattern of the unique source.

25. The system of claim 24, wherein the unique source synchronizes the energy emission with the perception frame rate of the energy detection device by receiving a synchronization signal from at least one of the energy detection device, the data analysis engine, or a source of a synchronization signal which is synchronized with the energy detection device, and

wherein the synchronization signal comprises at least one of an infrared signal, a magnetic signal, a radio frequency signal, a laser signal, an electromagnetic signal, or an audio signal.

26. The system of claim 23, wherein the unique source modulates the energy emission on and off according to the unique energy modulation pattern at a rate which is not synchronized with the perception frame rate of the energy detection device;

wherein the energy detection device determines when a received modulated energy emission from the unique source which is received by the energy detection device conforms to the energy modulation pattern of the unique source; and

wherein over a plurality of perception frames the energy detection device receives the unique energy modulation pattern of the unique source.

27. The system of claim 26, wherein the energy detection device determines that the received energy modulation pattern received from the unique source conforms to the energy modulation pattern of the unique source by at least one of determining that the received energy modulation pattern conforms to a previously detected energy modulation pattern of the unique source or by determining that the received energy modulation pattern detected from the unique source is an unambiguous energy modulation pattern.

28. The system of claim 22, further comprising a plurality of energy detection devices, wherein each energy detection device of the plurality of energy detection devices detects energy from the unique source within a field of view of the energy detection device, and wherein at least two of the energy detection devices have an overlapping field of view.

29. The system of claim 28, wherein each energy detection device of the plurality of energy detection devices determines location-related data of the unique source by determining at least one of an angular displacement or an energy intensity for the unique source within the field of view of the energy detection device.

30. The system of claim 29, wherein the data analysis engine combines a known location in relation to the three-dimensional space for each of the plurality of energy detection devices with at least one of the angular displacement for the unique source or with the energy intensity for the unique source within the field of view of each of the plurality of energy detection devices to determine the location of the unique source during the perception frame.

31. The system of claim 30, wherein the data analysis engine determines at least one of a path of movement of the unique source or an equation of motion of the unique source based on the location of the unique source during a plurality of perception frames.

32. The system of claim 31, wherein the data analysis engine extrapolates an extrapolated current position of the unique source based on at least one of a past location of the unique source, the path of movement of the unique source, or the equation of motion of the unique source.

33. The system of claim 31, wherein the data analysis engine determines that a newly identified source is the same as a previously identified unique source based on the location of the newly identified source and the extrapolated current position of the unique source.

34. The system of claim 22, wherein the unique source emits energy comprised of infrared light and wherein the energy detection device detects energy comprised of infrared light.

35. The system of claim 22, wherein a single period of time wherein energy may be emitted or energy may not be emitted from the unique source to signal a single bit in the energy emission pattern is an energy emission event; and

wherein the unique source is modulated on by at least one of emitting energy for greater than an on-modulation threshold period of time during the energy emission event or emitting energy at greater than an on-modulation threshold level of energy during the energy emission event; and

wherein the source is modulated off by at least one of emitting energy for less than an off-modulation threshold period of time throughout the duration of the energy emission event or emitting energy at less than an off-modulation threshold level of energy throughout the duration of the energy emission event.

* * * * *