



US 20080306708A1

(19) **United States**

(12) **Patent Application Publication**
GERMAIN, IV et al.

(10) **Pub. No.: US 2008/0306708 A1**
 (43) **Pub. Date: Dec. 11, 2008**

(54) **SYSTEM AND METHOD FOR ORIENTATION AND LOCATION CALIBRATION FOR IMAGE SENSORS**

Publication Classification

(51) **Int. Cl.**
G01B 11/03 (2006.01)

(75) **Inventors:** **Edward M. GERMAIN, IV**,
 McLean, VA (US); **David Page**,
 Falls Church, VA (US)

(52) **U.S. Cl.** **702/153**

Correspondence Address:
STERNE, KESSLER, GOLDSTEIN & FOX P.L.C.
1100 NEW YORK AVENUE, N.W.
WASHINGTON, DC 20005 (US)

(57) **ABSTRACT**

A system and method employing position measurement sensors and point sources of light to determine the location and orientation of video cameras in a simulation arena environment. In an embodiment, one or more accelerometers, gyroscopes, and/or magnetometers associated with each video camera may be used to determine the angular orientation of the video camera. The location of a camera is determined by measuring the distance from the camera to at least two known points, where the known points may be point sources of light, other cameras, or a combination thereof. Camera angular orientation information and camera location information may be combined to provide a complete set of data defining the position of each video camera.

(73) **Assignee:** **Raydon Corporation**, Daytona
 Beach, FL (US)

(21) **Appl. No.:** **12/132,423**

(22) **Filed:** **Jun. 3, 2008**

Related U.S. Application Data

(60) Provisional application No. 60/942,038, filed on Jun. 5, 2007.

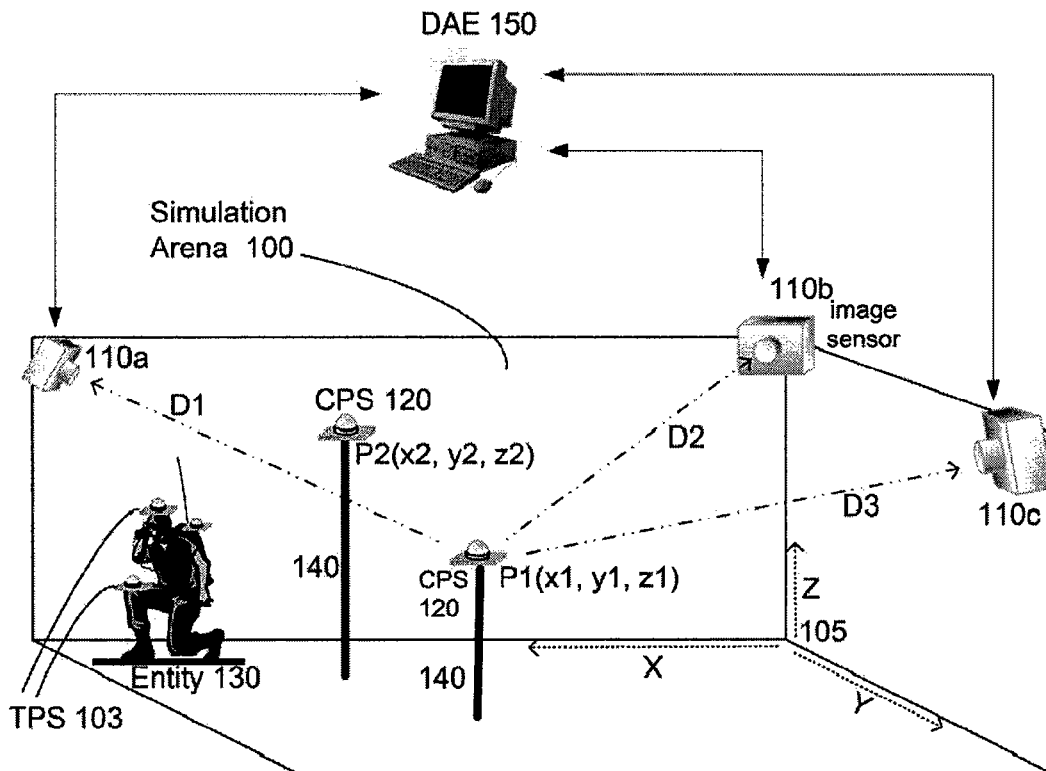

[0062]Image sensors 110 are mounted in such a way that each one of the image sensors 110 has a field of view which at least partially overlaps with the field of view of at least one other of the plurality of image sensors 110. These image sensors 110 are the visual tracking devices (VTDs) which monitor the position of entities 130 in the simulation arena 100. The image sensors 110 may be mounted in the periphery, or the interior, or both the periphery and interior, of a bounded volume of space to be monitored.

[0063]FIG. 1 illustrates an exemplary embodiment only, in which only three image sensors 110 are in use. More or fewer image sensors 110 may be used, and the locations of the image sensors are not limited to the upper corners of an arena 100.

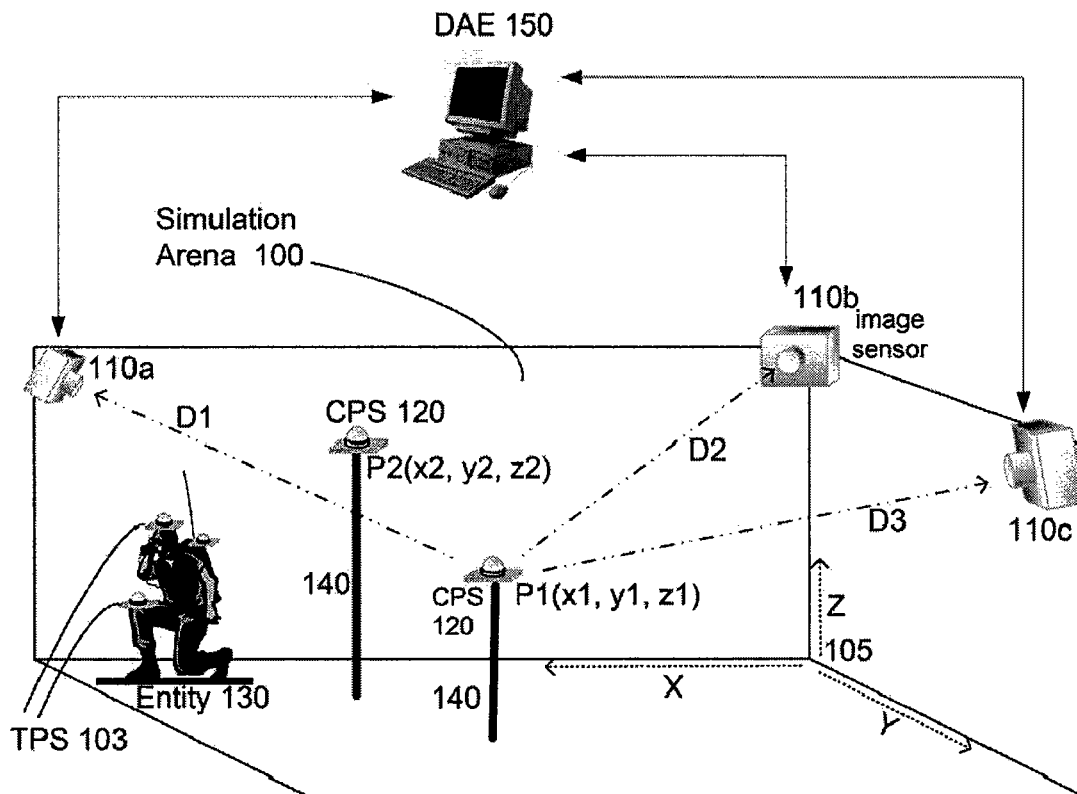

FIG. 1

[0064]The arena 100 is generally understood as the bounded volume of space wherein a simulation or gaming event may be conducted. The boundaries of the bounded volume of space may be defined by walls or other delimiters or markers, and substantially all or most of the bounded volume of space will be monitored by the plurality of image sensors 110. However, the arena 100 may also be understood to be defined topologically as the set of all points which are visible to two or more image sensors 110, since at least two image sensors 110 may be needed to identify the location of an entity 130 in the arena.

[0066]FIG. 1 also shows how an exemplary coordinate system 105 may be imposed upon the arena 100 for the purpose of identifying the location of TPSs 103 and CPSs 120 (discussed further immediately below) within the arena. The locations of the image sensors 110 may also be identified in relation to this same coordinate system. A conventional Cartesian coordinate system 105 with three orthogonal coordinate axes (x, y, z) is illustrated, with its origin at one corner of the arena; however, other coordinate systems may be used including, for example and without limitation, a spherical coordinate system or a cylindrical coordinate system.

[0076] FIG. 2 illustrates a system for calibrating the position of an image sensor. In an exemplary embodiment, the system requires:

[0077] a defined arena coordinate system 105;

[0078] the image sensor 110 itself, including in particular the image sensor imaging element or backplane 205;

[0079] at least two CPSs 120 at known, fixed positions P1 and P2;

[0080] a means 210, such as a PMD 210, for determining the angular orientation θ of the image sensor 205 in relation to the arena coordinate system 105.

[0081] By means of these elements, it is possible to determine the distances D_1 , D_2 from image sensor 110 to the CPSs 120, as will be discussed further below. As also discussed further below, with D_1 and D_2 determined, it is possible to further determine the location $P_s(x_s, y_s)$ of image sensor 110.

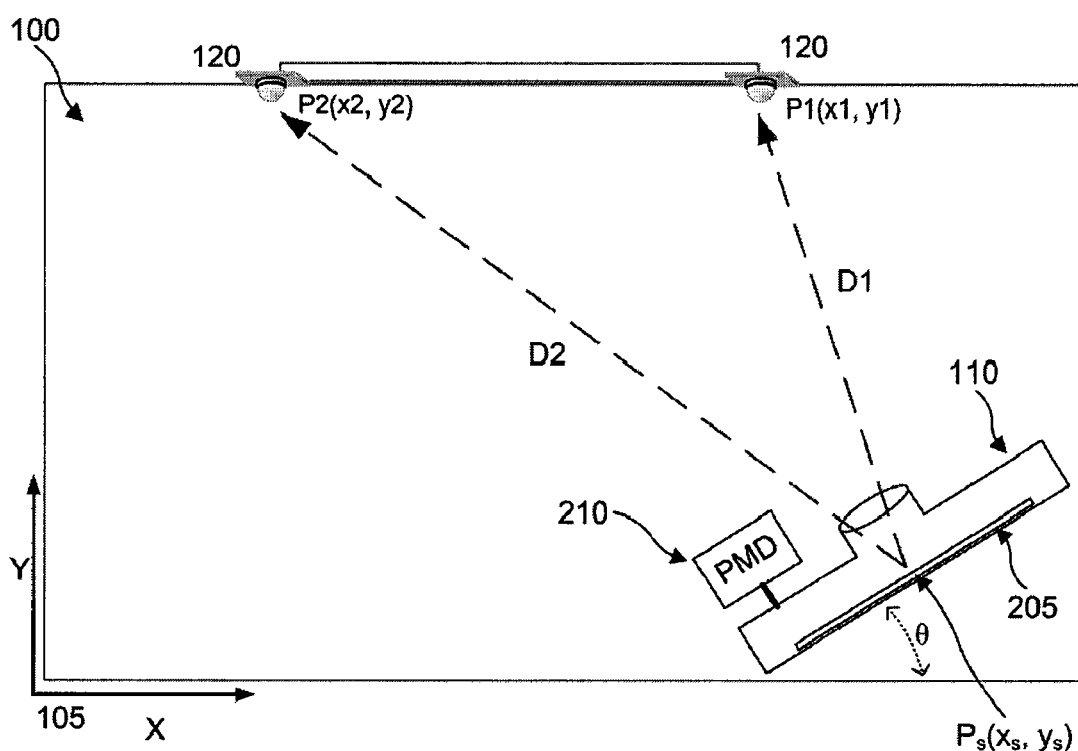

FIG. 2

[0083] In an exemplary embodiment of the present invention, a first step in sensor position calibration entails determining the orientation of the image sensor. For example, the image sensor orientation may be measured using a positional measurement device (PMD). FIG. 2 illustrates an image sensor 110 with an associated PMD 210. In an exemplary embodiment the PMD 210 may be comprised of a combination of accelerometers and gyroscopes (not shown) combined on a single platform. PMD 210 may also be composed only of one or more accelerometers, or one or more gyroscopes, or other means for determining the angular orientation of image sensor 110.

[0084] The PMD 210 may be a separate unit, which is then attached to the image sensor 110 (for example, attached to the camera's base); or the PMD 210 may be integrated into image sensor 110.

[0091] In an exemplary embodiment of the present method, the location of image sensor 110 can be determined provided the following parameters are established or can be measured:

[0092] (1) A coordinate system 105 for elements within the arena 100, which is hence known as the arena coordinate system.

[0093] (2) The position of at least two known points P1 and P2 in the arena 100, with their position defined relative to the arena coordinate system 105, and wherein the two known points P1 and P2 are within the field of view of the image sensor 110. Various means for initially determining the locations of known points P1 and P2 have already been discussed above.

[0094] (3) A means for the image sensor 110 to obtain an image of the two known points P1 and P2. As already discussed above, this may be accomplished by fixing CPSs 120 at points P1 and P2, or by other means.

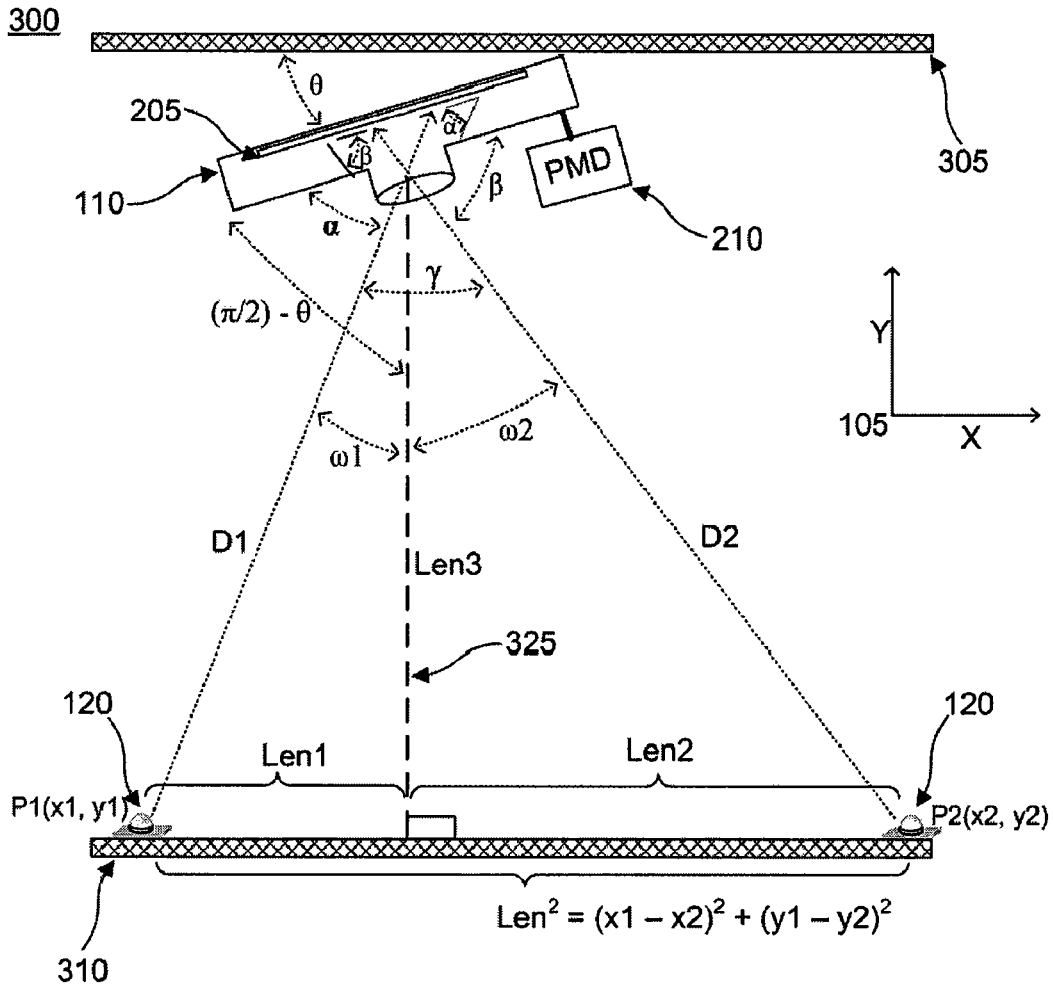

FIG. 3

[0095] (4) The angular separation .gamma. between the points P1 and P2, relative to the image sensor 110. In an exemplary embodiment of the present invention, an equivalent determination are the respective angles of incidence .alpha., .beta. on a backplane 205 of image sensor 110 of rays of light D1, D2 from CPSs 120 located at respective points P1, P2.

[0096] (5) The angular orientation .theta. of image sensor 110 relative to the arena coordinate system 105. This is determined by PMD 210 attached to image sensor 110.

{Detailed calculations are presented in the full patent application.}

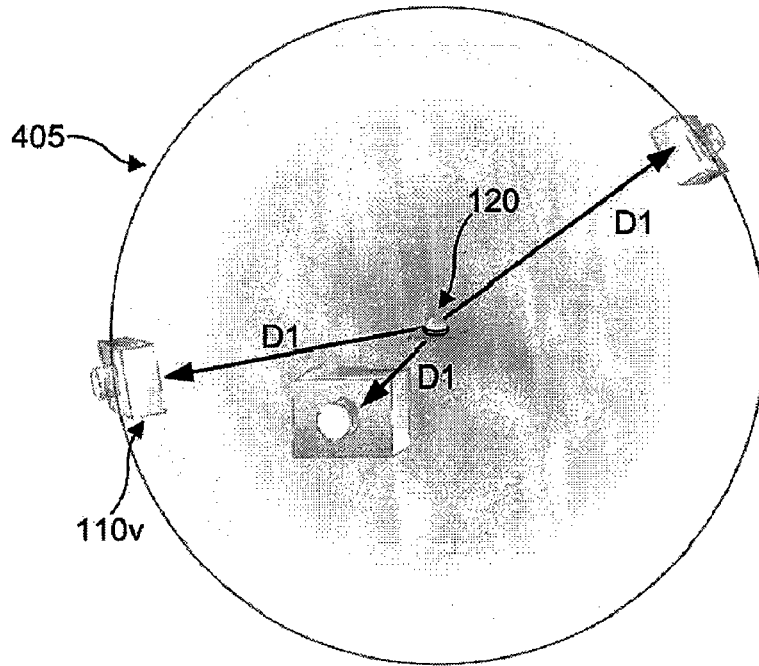

FIG. 4A

[0112] The position of the image sensor may be defined as $P_{sub.s}(x_{sub.s}, y_{sub.s}, z_{sub.s})$ which, in an exemplary embodiment, may be the position of the focal point of the image sensor 110 image plane 205. Equations for the position of the image sensor may then be derived of the form:

$$(x_{sub.s}-x_1).sup.2+(y_{sub.s}-y_1).sup.2+(z_{sub.s}-z_1).sup.2=D1.sup.2$$

...

$$(x_{sub.s}-x_N).sup.2+(y_{sub.s}-y_N).sup.2+(z_{sub.s}-z_N).sup.2=(DN.sup.2$$

[0113] Each of these equations may be recognized as standard equations for spheres, wherein each sphere S_1, \dots, S_N is centered around a respective known point $P_1(x_1, y_1, z_1), \dots, P_N(x_N, y_N, z_N)$; unknown point $P_{sub.s}(x_{sub.s}, y_{sub.s}, z_{sub.s})$, i.e., the unknown location of the image sensor 110v, is located somewhere on the surface of the sphere. This is illustrated in FIG. 4A, where the multiple image sensors 110v on the surface of sphere 405 are shown as partly transparent, indicating that they all represent "virtual" image sensors at potential locations of the actual image sensor. Note that all of these virtual image sensors 110v are at the same distance D_1 from CPS 120. Further note that image sensor 110v may be anywhere on the surface of sphere 405; the three locations illustrated are exemplary only.

[0114] At a minimum, at least two known points P_1, P_2 must be in the field of view of the image sensor. In this case (i.e., only two known points are in the field of view), a joint solution of the two resulting sphere equations is an equation of a circle 410 in three-dimensional space. Image sensor 110v lies somewhere along circle 410.

{Shown in shown in FIG. 4B in the full application.}

[0115] FIG. 5 illustrates in part a method by which the exact location of the image sensor 110 may be further resolved. Specifically, the method entails determining the equation of a line extending from image sensor 110 to CPS 120.

[0116] In an exemplary embodiment of the present invention, PMD 210 associated with image sensor 110 can provide the mounting angles (θ , ψ , ξ) of image sensor 110 in relation to arena coordinate system 105. Moreover, image sensor 110 provides the two-dimensional angles of incidence (α_1 , α_2) on the backplane 205 of image sensor 110 of the ray of light D1 from CPS 120 at a point P1. (This angular determination of the angle of incidence of rays of light on backplane 205 is discussed further below.)

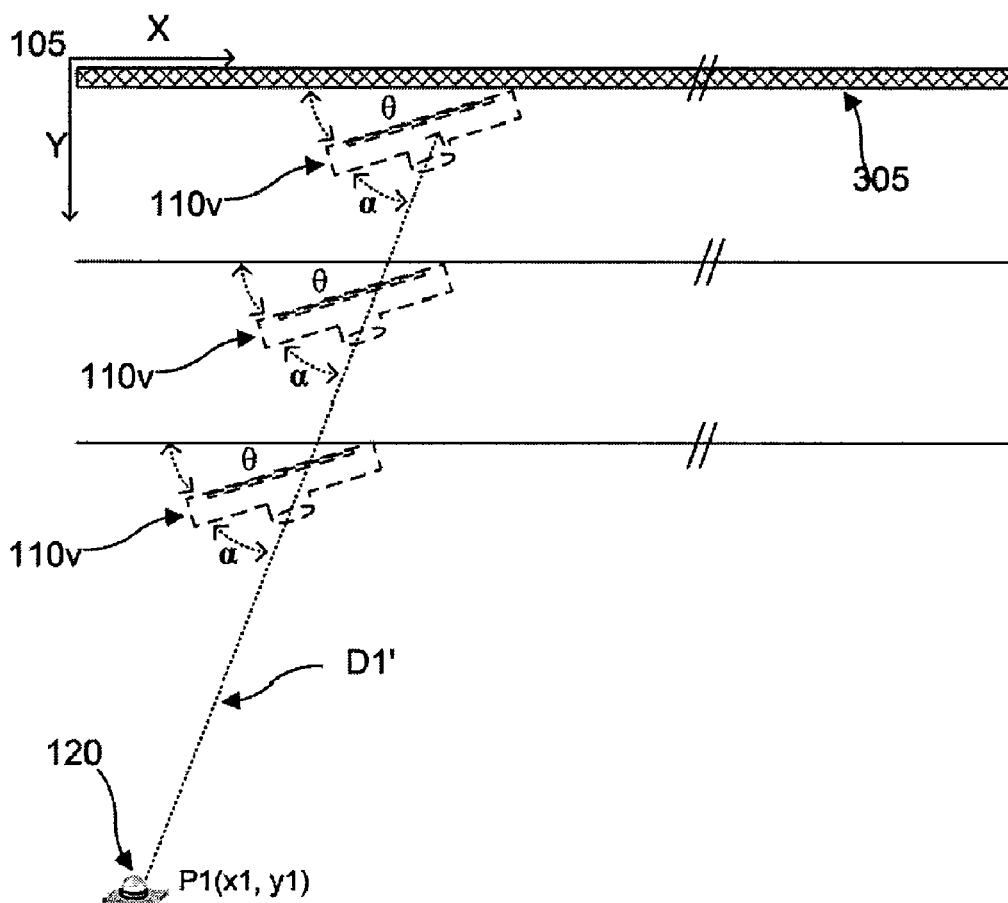

FIG. 5

[0118] Using the parameters shown in FIG. 5, the two dimensional equation for the line (i.e., the ray of light) D1' extending from P1 at known position (x_1, y_1) , and consistent with the known image sensor-related angles θ and α as illustrated, is given by: $y - \tan(\theta + \alpha) * x = y_1 - \tan(\theta + \alpha) * x_1$

[0119] . . . where, since y_1 , x_1 , θ and α are known values, the expression on the right-hand side of the equation (i.e., $y_1 - \tan(\theta + \alpha) * x_1$) can be calculated to yield a constant value.

[0121] As illustrated in FIG. 5 by the several exemplary "virtual" image sensors 110v (wherein the virtual image sensors have dotted-line boundaries), the actual image sensor 110 must lie somewhere along line D1'.

[0122]FIG. 6 as drawn is assumed to be a top-down view of an essentially two-dimensional arena space, where P1, P2, and image sensor 110 are assumed to be co-planar (for example, all three on the floor of arena 100, or all three on the ceiling of arena 100.) From this perspective, circle 410 would be orthogonal to the plane of the drawing, and is therefore drawn as it would actually be seen from this perspective, namely as line 410. Dotted oval 410' is presented as an aid to visualization of circle 410, indicating circle 410 extending into and out of the plane of the figure.

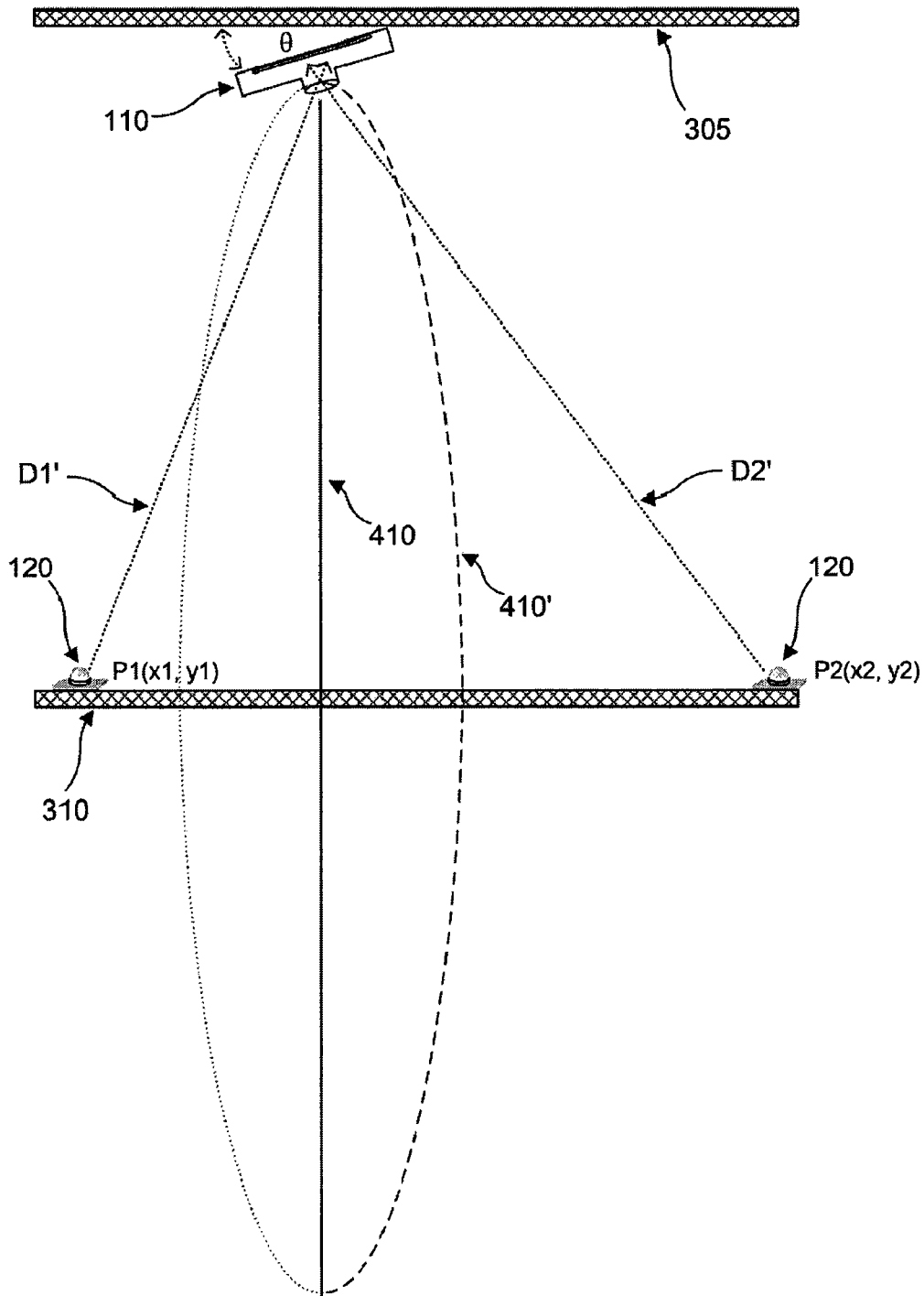

[0123]As illustrated in FIG. 6, since there are at least two such camera/known-point lines D1', D2' (corresponding to known points P1 and P2), it is possible to resolve the location of image sensor 110 as the intersection of lines D1', D2' with previously established circle 410. Put another way, solving for the intersection of camera/known-point lines D1', D2' and circle 410 yields the location of the camera in three-dimensional space.

FIG. 6

[0125] FIG. 7A and FIG. 7B together illustrate a method for locating a CPS 120 in an image sensor 110 field of view, and hence for identifying an angle α , or pair of angles (α_1, α_2), where α represents an angle of incidence of a ray of light D1, D2, etc., from a CPS 120 onto backplane 205 of image sensor 110.

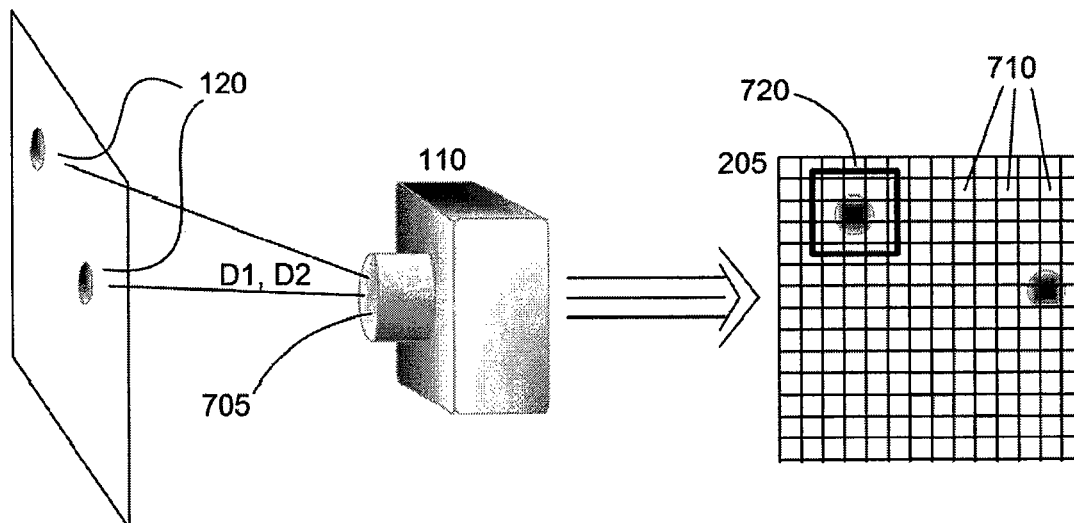

FIG. 7A

[0126] FIG. 7A illustrates image sensor 110 observing two CPSs 120, with rays of light D1, D2 from CPSs 120 striking a lens or other optical element 705 of image sensor 110. The lens or other optical elements 705... focuses rays of light D1, D2 from CPSs 120 onto backplane 205 (i.e., the imaging element) of image sensor 110. The backplane 205 is here represented as a matrix of discrete pixel elements 710 (i.e., sensor cells), which may be physical pixel elements, or which may be logical pixel elements derived from a scanning process or similar process Together, discrete pixel elements 710 comprise a digitized field of view of CPSs 120 within the field of view of image sensor 110. Each CPS 120 light source may be perceived by image sensor 110 as a heightened area of sensed light intensity in a bounded area 720 of the digitized field of view.

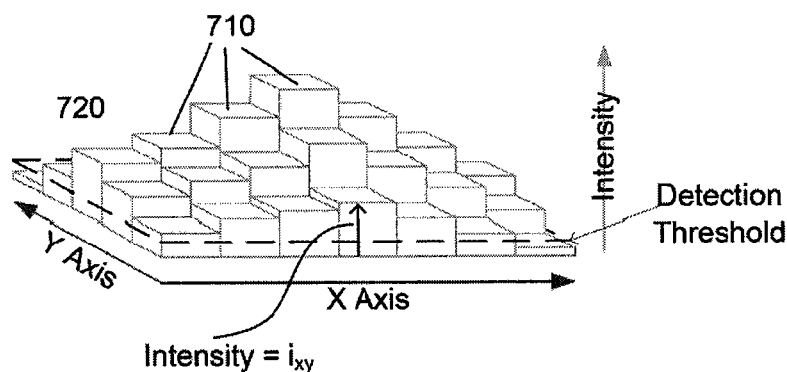

FIG. 7B

[0127] FIG. 7B illustrates how different pixel elements or sensor cells 710 in the bounded area of detection 720 may detect different degrees of light intensity. In the figure, the light intensity is exemplified by the height of a pixel element 710. (The "height" is representational only, corresponding to a recorded light intensity, and does not correspond to a physical, structural height of a pixel in a physical backplane or imaging element.) Pixel element 710 may only be considered to have detected light from a CPS 120 if the measure of light intensity from the pixel element 710 exceeds a threshold value. {Fig. 7B is discussed further in the application.}

SYSTEM AND METHOD FOR ORIENTATION AND LOCATION CALIBRATION FOR IMAGE SENSORS

CROSS REFERENCE TO RELATED APPLICATION

[0001] This application claims priority to U.S. provisional application "System and Method For Orientation and Location Calibration for Image Sensors", filed on Jun. 5, 2007, U.S. application No. 60/942,038, which is co-owned with the current application and which is incorporated by reference herein in its entirety as if reproduced in full below.

[0002] This application is related to copending U.S. application "Simulation Arena Entity Tracking System", filed on Nov. 6, 2006, U.S. application Ser. No. 11/593,066 (attorney docket number 2477.0040001), which is co-owned with the current application and which is incorporated by reference herein in its entirety as if reproduced in full below.

BACKGROUND

[0003] 1. Field of the Invention

[0004] This invention relates to tracking the position and motion of one or more entities in a three-dimensional space, and in particular to calibrating the position(s) of one or more image sensors.

[0005] 2. Background Art

[0006] As understood in this document, a simulation is a physical space in which real people and/or real objects may move, change location, possibly interact with each other, and possibly interact with simulated people and/or simulated objects (whose presence may be enacted via visual projections, audio emissions, or other means) typically in order to prepare for, experience, or study real-life, historical, anticipated, or hypothetical activities or events. Simulations may be conducted for other purposes as well, such as educational or entertainment purposes, or for analyzing and refining the design and performance of mechanical technologies (such as cars or other transportation vehicles, a wide variety of robotic technologies, weapons systems, etc.). The simulation as a whole may also be understood to include any technology which may be necessary to implement the simulation environment or simulation experience.

[0007] A simulation may be conducted in an environment known as a simulation arena (or simply as an arena, for short). Realistic simulations of events play a key role in many fields of human endeavor, from the training of police, rescue, military, and emergency personnel; to the development of improved field technologies for use by such personnel; to the analysis of human movement and behavior in such fields as athletics and safety research. Increasingly, modern simulation environments embody simulation arenas which strive for a dynamic, adaptive realism, meaning that the simulation environment can both provide feedback to players in the environment, and can further modify the course of the simulation itself in response to events within the simulation environment. It may also be desirable to collect the maximum possible amount of data about events which occur within the simulation environment, since such data can be used for reporting, analysis, and related purposes.

[0008] For a simulation to be adaptive, the technology controlling the simulation arena (where such technology may be a combination of hardware and software) may require information on activity within the simulation environment. A com-

ponent of this information may be data on the location and movement of people and objects within the simulation environment. A person and/or object within the simulation environment may be referred to generically as a "simulation entity", or as an "entity", or the plurals thereof (i.e., "entities").

[0009] The more specific the location data and movement data which may be obtained on simulation entities, the more detailed and refined can be the simulation responses. For example, it is desirable to obtain information not only on where a person might be located, but even more specific information on where the person's hands, head, or feet might be at a given time. A location granularity on the order of feet or meters is highly desirable, and even more fine-grained location discrimination (such as on the order of inches or centimeters) is desirable as well. It is further desirable to be able to determine the orientation in space of people and objects, as well as their rotational motion.

[0010] As a consequence, reliable, accurate, and precise location monitoring is a desirable feature of a simulation environment. One means to accomplish this monitoring is video tracking in three dimensions, where one or more cameras may be used to monitor the location and track the movement of entities in the simulation arena. One example of such a simulation arena video tracking system is described in the pending application "Simulation Arena Entity Tracking System", filed on Nov. 6, 2006, U.S. application Ser. No. 11/593,066. As described in the aforementioned application, determination of the position of entities in the arena environment may be accomplished using video cameras or similar cameras to track entity location and movement.

[0011] In turn, to achieve reliable location determination and entity tracking, it is desirable to have specific and detailed knowledge of the location and orientation of the video cameras within the simulation arena. In particular, the use of multiple cameras in an entity tracking environment requires that images of a single entity be accurately correlated from among images provided by multiple video cameras. This, in turn, may require a high degree of resolution of both the location and the angular orientation of each video camera.

[0012] However, in the installation of video cameras in the arena environment, there is no guarantee of an exact placement and angular offset. In other words, even though a simulation arena design may indicate a specific placement and orientation of a video camera or cameras, the designated camera location and orientation may not conform with sufficient accuracy to the design specifications.

[0013] For example, an arena may be constructed in a conventional space with planar, orthogonal walls. A reference set of spatial coordinates may be established using standard, orthogonal Cartesian coordinates, with the origin of the coordinate system at one corner of the arena space, and with the axes of the coordinate system coinciding with the physical vertices of the walls. In this case, it may prove relatively straightforward to accurately identify the locations of some video cameras, particularly those which are mounted directly on the exterior walls which bound the arena environment, using mechanical measurements, provided the measurements were made with precision and care.

[0014] However, it may also be necessary to mount additional monitoring cameras at points on the interior of the arena space, possibly in some cases suspended from various elements of the simulation which themselves may not be entirely structurally stable (e.g., real or artificial trees). Mak-

ing reliable and accurate measurements of the locations of these interiorly mounted video cameras relative to the arena coordinate system may prove to be problematic.

[0015] In addition, it may be beneficial to the simulation to have some cameras mounted on elements of the simulation which are in motion, or even on simulation entities (i.e., simulation participants) themselves. Such mobile video cameras, while helpful to monitoring events within the simulation arena, may need frequent position determination and recalibration.

[0016] Further, it is possible that the physical space of the simulation arena does not lend itself to firm, flat, orthogonal walls, or similarly symmetric structures (such as a perfectly cylindrical perimeter wall) which may be convenient for establishing simulation arena coordinates. The walls or perimeter of the simulation arena may be irregular, or the simulation may even be conducted in an outdoor environment. Defining the simulation arena's physical coordinates in these circumstances may prove challenging, which further compounds the challenges of determining the exact location and orientation of cameras used to monitor the simulation.

[0017] What is needed, then, is a system and method for easily and reliably determining the orientation and location of cameras in a simulation arena.

SUMMARY

[0018] The current invention improves on camera tracking technology by providing a solution to measuring the mounting position of a video camera. This system may be used with any number of cameras. By accurately calibrating the positions of multiple cameras, it becomes possible to correlate tracked objects between views provided by different cameras. The invention is composed of three main components that work together to provide substantially accurate orientation/location measurements.

[0019] The first of these elements is the position measurement device (PMD). In one embodiment, the position measurement devices comprise a three-axis accelerometer and a two-axis magnetometer.

[0020] The second component comprises one or more image sensors. In one embodiment, an image sensor may be a black-and-white CMOS video camera with an infrared filter attached.

[0021] The third component comprises one or more known tracking point sources (TPSS). In one embodiment, the known tracking point sources are infrared light emitting diodes (LEDs), where the infrared light is in the spectra visible to the image sensors. When a TPS is used to calibrate the location of image sensors, the TPS may also be known as a calibration point source (CPS).

[0022] The system is calibrated by measuring the mounting angle of each camera with a position measurement device (PMD). Then, the distance to two or more known CPSs, or to two or more known cameras, or to a combination of two or more known CPSs and/or known cameras is measured. With these measurements, the location of each camera can be resolved.

BRIEF DESCRIPTION OF THE DRAWINGS/FIGURES

[0023] The features and advantages of the present invention will become more apparent from the detailed description set

forth below when taken in conjunction with the drawings in which like reference numbers indicate identical or functionally similar elements.

[0024] Additionally, the left-most digit of a reference number identifies the drawing in which the reference number first appears (e.g., a reference number '310' indicates that the element so numbered first appears in FIG. 3). Further, elements which have the same reference number followed by a different letter of the alphabet or other distinctive marking (e.g., an apostrophe) indicate elements which may be the same or substantially similar in structure, operation, or form, but may be identified as being in different locations in space or recurring at different points in time.

[0025] FIG. 1 illustrates an arena where simulation event takes place, and where energy-emitting tracking point sources (TPSS) attached to entities (people or objects) may be used to monitor entity motion in the arena; and also where the TPSSs, some of which are calibration point sources (CPSs), also may be used to help calibrate the position of image sensors in the arena.

[0026] FIG. 2 illustrates a system for orientation and location calibration for image sensors.

[0027] FIG. 3 illustrates in detail the calculations involved when a single image sensor calibrates its orientation and location in the arena by imaging two CPSs.

[0028] FIG. 4A illustrates that when an image sensor images a single CPS, a determination may be made that the image sensor is located somewhere along the surface of a sphere in space.

[0029] FIG. 4B illustrates that when an image sensor images two CPSs, a determination may be made that the image sensor lies somewhere along a specific circle in space.

[0030] FIG. 5 illustrates the determination of a line in space between a CPS and an image sensor, as a means of further resolving the location of the image sensor.

[0031] FIG. 6 illustrates the determination of the location in space of an image sensor based on both a previously determined circle of possible locations and a pair of previously determined lines of location.

[0032] FIG. 7A and FIG. 7B together illustrate an approach for identifying an angle of incidence of light, on an image sensor backplane, of light coming from a CPS.

[0033] FIG. 8 illustrates representative front and side views of an image sensor with a built-in, front mounted CPS.

[0034] FIG. 9 illustrates an exemplary computer system configured to run software suitable for the present system and method.

[0035] Further embodiments, features, and advantages of the present invention, as well as the operation of the various embodiments of the present invention, are described below with reference to the accompanying figures.

DETAILED DESCRIPTION

[0036] One or more embodiments of the present invention are now described with reference to the figures. While specific configurations and arrangements are discussed, it should be understood that this is done for illustrative purposes only. A person skilled in the relevant art(s) will recognize that other configurations and arrangements can be used without departing from the spirit and scope of the invention. It will be apparent to a person skilled in the relevant art(s) that this invention can also be employed in a variety of other systems and applications.

[0037] A list of the major sections of this detailed description follows:

1. Definitions and Characterizations of Elements and Technologies Which May Be Employed In or Related to The Present Invention
2. The Simulation Arena Environment
3. A System For Determining The Location Of An Image Sensor
4. A Method For Determining The Location Of An Image Sensor
5. Determining the Angle of Incidence of Light On the Image Sensor Backplane
6. Eliminating Skew Errors
7. Visual Tracking Systems With Two Or More Cameras
8. Image Sensors, the Arena Data Analysis Engine, and Data Processing Elements
9. Summary

[0038] 1. Definitions and Characterizations of Elements and Technologies which May Be Employed in or Related to the Present Invention

[0039] Simulation arena or simulation environment—The term “arena” has already been discussed above in some detail. Briefly and in general terms, the arena is the physical space in which a simulation is conducted. The terms “simulation environment”, or simply “environment”, may be taken somewhat more broadly to include both the physical space used by the simulation (i.e., the arena proper) and also the various technologies and other elements which contribute to the simulation experience. However, such terms as “simulation arena”, “simulation environment”, “arena environment”, and similar combinations of terms may be used interchangeably in this document where the context of the discussion makes the scope of the phrase apparent.

[0040] Entity—A person, other living being, or object within a simulation arena, typically excluding some, most, or all of the infrastructure objects or technologies used to enable the simulation process itself (e.g., excluding lighting fixtures; fixed, stationary structures; image sensors; tracking point sources; cabling, etc.). Entities are generally the living beings and/or physical objects which are, in the art, viewed as players or participants in the simulation, and whose locations and/or movements may be tracked during the course of the simulation.

[0041] Visual tracking system—A system used to determine the location of entities, which are typically entities within a simulation arena. A visual tracking system may comprise a single image sensor, or may comprise multiple image sensors (i.e., an image sensor array), wherein the image sensor or image sensors detect entities within their field of view. A visual tracking system may further comprise a means for analyzing and/or integrating location data provided by one or more image sensors; the means may be a computer (e.g., a desktop computer or laptop computer), a microprocessor, a data analysis engine (DAE), or other data processing technology or system.

[0042] Image sensor—Except where otherwise noted, the following terms are used synonymously throughout this document: image sensor, camera, video camera, visual tracking device (VTD), energy detection device, and the respective

plurals thereof. All such terms may be understood as referring to a device that may encompass at least the capabilities for obtaining a time-series of images as typically embodied by a standard video camera. That is, an image sensor may be understood as referring to a device which captures light energy in a field of view, and which focuses the light energy on an image detecting element or image plane, thereby detecting a series of images over time for the purpose of detecting and capturing the location or movement of objects in the field of view of the image sensor. An image sensor may detect a series of images at a typical frame rate on the order of tens of image frames per second.

[0043] However, it should be further understood that an image sensor may embody other capabilities or modified capabilities as well. These capabilities may include, for example and without limitation, the ability to obtain image data based on energy in the infrared spectrum or other spectral ranges outside of the range of visible light; the ability to modify or enhance raw captured image data; the ability to perform calculations or analyses based on captured image data; the ability to share image data or other data with other technologies over a network or via other means; or the ability to emit or receive synchronization signals for purposes of synchronizing image recording, data processing, and/or data transmission with external events, activities, or technologies.

[0044] Other enhanced capabilities, adaptations, or modifications of an image sensor as compared with a standard video camera may be described further below in conjunction with various embodiments of the present invention. In one embodiment, an image sensor may be a black-and-white CMOS video camera with an infrared filter attached.

[0045] Camera comprised of multiple image sensing units—In some cases, it may be specifically indicated that a single camera, single video camera, or single image sensor may be comprised of two or more discrete image sensing units. Typically, such a video camera employs the two discrete image sensing units as a means to provide stereoscopic imaging, i.e., imaging with depth information.

[0046] Positional measurement device (PMD)—The following terms may be used synonymously throughout this document: positional measurement device, PMD, orientation measurement device, orientation measuring device, orientation sensing device, orientation sensor, angular orientation measurement device, angular orientation measuring device, angular orientation sensing device, angular orientation sensor, and the respective plurals thereof. All such terms may be understood as referring to a class of technologies which can determine, in part or in whole, an angular orientation of an object or entity relative to some designated angular frame of reference.

[0047] Positional measuring devices (PMDs) may include accelerometers, magnetometers, gyroscopes, or other orientation sensors. An accelerometer can measure the direction of the gravity vector to determine positional angles. A magnetometer can measure the direction of a localized magnetic field or Earth’s magnetic field. A gyroscope can measure angle of tilt off of level.

[0048] Tracking point source (TPS)—The following terms may be used synonymously throughout this document: point source, tracking point source, TPS, source of energy emission, energy emitting device, and the respective plurals thereof.

[0049] A tracking point source may be understood as an energy emitting device which is physically small compared to

sented for example purposes only. The architecture of the present invention is sufficiently flexible and configurable, such that it may be utilized and implemented in ways other than that shown in the accompanying figures.

What is claimed is:

1. In a simulation environment having a coordinate system, the simulation environment including an image sensor, and a plurality of point sources of light each at a respective fixed and identified location in relation to the coordinate system, a method of determining a position of the image sensor, comprising:

- (a) determining an angular orientation of the image sensor in relation to the coordinate system;
- (b) determining a plurality of respective distances from the image sensor to the plurality of point sources of light; and
- (c) calculating a position of the image sensor in relation to the coordinate system based on the angular orientation and the plurality of respective distances.

2. The method of claim 1, wherein step (a) comprises determining the angular orientation via an angular orientation determining element associated with the image sensor.

3. The method of claim 2, wherein determining the angular orientation via the angular orientation determining element comprises determining the angular orientation via at least one of an accelerometer, a magnetometer, or a gyroscope associated with the image sensor.

4. The method of claim 1, wherein step (b) comprises determining respective angles of incidence of light from the plurality of point source of light at the image sensor.

5. The method of claim 4, wherein step (b) further comprises performing a distance calculation based on: the respective angles of incidence; and a distance between at least a pair of point sources of light of the plurality of point sources of light.

6. The method of claim 5, wherein the step of performing a distance calculation further comprises determining the distance between the at least a pair of point sources of light based on the respective fixed and identified location in relation to the coordinate system of each point source of light of the at least a pair of point sources of light.

7. The method of claim 1, wherein the image sensor comprises a stereoscopic image sensor; and step (b) comprises performing a distance calculation based on a stereoscopic imaging of the plurality of point sources of light.

8. The method of claim 1, wherein step (c) comprises:

- (i) determining equations which define a plurality of spheres, wherein each sphere of the plurality of spheres is centered at a coordinate location of a respective point source of light of the plurality of point sources of light, and wherein each sphere has a respective radius equal to a respective distance from the image sensor to the respective point sources of light.

9. The method of claim 8, wherein step (c) further comprises:

- (ii) determining an intersection of the spheres, wherein the intersection comprises at least one of a circle, a set of points, or a point.

10. The method of claim 9, wherein step (c) further comprises:

- (iii) calculating the position based on the point of intersection of the spheres.

11. The method of claim 9, wherein step (c) further comprises:

- (iii) determining an equation of a line from the image sensor to a point source of light of the plurality of point sources.

12. The method of claim 11, wherein determining the equation of the line from the image sensor to the point source of light comprises determining the equation of the line based on: the respective fixed and identified location of the point source in relation to the coordinate system; the angular orientation of the image sensor in relation to the coordinate system and an angle of incidence of light from the point source of light at the image sensor.

13. The method of claim 11, wherein step (c) further comprises:

- (iv) calculating an intersection of the line with the intersection of the spheres.

14. In a simulation environment having a coordinate system, an image sensor location determination system comprising:

- an image sensor;
- a plurality of point sources of light each at a respective fixed and identified location in relation to the coordinate system;
- at least a processor; and
- a memory in communication with the at least a processor; wherein:

the image sensor is configured to determine an orientation of the image sensor in relation to the coordinate system; and

the memory stores a plurality of processing instructions for directing the at least a processor to determine a position of the image sensor in relation to the coordinate system based on:

- the orientation of the image sensor; and
- a plurality of respective distances from the image sensor to the plurality of point sources of light.

15. The system of claim 14, wherein the at least a processor comprises at least one of a processor of the image sensor or a processor of a computer of the simulation environment.

16. The system of claim 14, further comprising an angular orientation determining element associated with the image sensor, the angular orientation determining element configured to determine the orientation of the image sensor in relation to the coordinate system.

17. The system of claim 16, wherein the angular orientation determining element comprises at least one of an accelerometer, a magnetometer, or a gyroscope associated with the image sensor.

18. The system of claim 14, wherein the instructions for directing the at least a processor to determine the location of the image sensor comprise instructions to determine the plurality of respective distances from the image sensor to the plurality of point sources of light.

19. The system of claim 18, wherein the instructions for directing the at least a processor to determine the plurality of respective distances comprise instructions to calculate the plurality of respective distances based on the respective fixed and identified locations in relation to the coordinate system of the plurality of point sources of light.

20. The system of claim 18, wherein the instructions for directing the at least a processor to determine the plurality of respective distances comprise instructions to calculate the

plurality of respective distances based on the orientation of the image sensor in relation to the coordinate system.

21. The system of claim **18**, wherein the instructions for directing the at least a processor to determine the plurality of respective distances comprise instructions to calculate the plurality of respective distances based on a plurality of respective angles of incidence at the image sensor of light from the plurality of point sources.

22. The system of claim **21**, wherein:

the image sensor is configured to detect an incidence of light from the plurality of point sources of light; and the instructions for directing the at least a processor to determine the plurality of respective distances further comprise instructions to determine the plurality of respective angles of incidence at the image sensor of light from the plurality of point sources based on the detected incidence of light from the plurality of point sources.

23. The system of claim **21**, wherein:

the image sensor further comprises an imaging element; and

the instructions for directing the at least a processor to determine the plurality of respective angles of incidence at the image sensor of light from the plurality of point sources comprise instructions to determine the plurality of respective angles of incidence based on at least one of: a location on the imaging element of a ray of light; or an intensity at the imaging element of the ray of light.

24. The system of claim **18**, wherein:

the image sensor further comprises a stereoscopic image sensor; and

the instructions for directing the at least a processor to determine the plurality of respective distances comprise instructions to determine a distance based on a stereoscopic imaging of the plurality of point sources.

25. The system of claim **14**, wherein the instructions for directing the at least a processor to determine the position of the image sensor in relation to the coordinate system further comprise instructions to determine equations which define a plurality of spheres, wherein:

each sphere of the plurality of spheres is centered around a respective point source of light of the plurality of point sources; and

each sphere has a respective radius equal to the respective distances from the image sensor to the respective point sources of light.

26. The system of claim **25**, wherein the instructions for directing the at least a processor to determine the position of the image sensor in relation to the coordinate system further comprise instructions to determine an intersection of the spheres, wherein the intersection comprises at least one of a circle, a set of points, or a point.

27. The system of claim **26**, wherein the instructions for directing the at least a processor to determine the position of the image sensor in relation to the coordinate system further comprise instructions to calculate the position based on the point of intersection of the spheres.

28. The system of claim **26**, wherein the instructions for directing the at least a processor to determine the position of the image sensor in relation to the coordinate system further comprise instructions to determine an equation of a line from the image sensor to a point source of light of the plurality of point sources.

29. The system of claim **28**, wherein the instructions for directing the at least a processor to determine the equation of a line from the image sensor to the point source of light further comprise instructions to determine the equation of the line based on:

the respective fixed and identified location of the point source in relation to the coordinate system;

the angular orientation of the image sensor in relation to the coordinate system and

an angle of incidence of light from the point source of light at the image sensor.

30. The system of claim **28**, wherein the instructions for directing the at least a processor to determine the position of the image sensor in relation to the coordinate system further comprise instructions to determine an intersection of the line with the intersection of the spheres.

31. A computer program product comprising a computer usable medium having control logic stored therein for causing the computer to determine a position of an image sensor in relation to a coordinate system of a simulation environment, the control logic comprising:

first computer readable program code means for causing the computer to receive for a plurality of point sources of light of the simulation environment a plurality of respective fixed and identified locations of the point sources in relation to the coordinate system;

second computer readable program code means for causing the computer to determine the angular orientation of the image sensor in relation to the coordinate system;

third computer readable program code means for causing the computer to calculate a plurality of respective distances from the image sensor to the plurality of point sources of light; and

fourth computer readable program code means for causing the computer to calculate the position of the image sensor in relation to the coordinate system based on the angular orientation and the plurality of respective distances.

32. The computer program product of claim **31**, wherein said second computer readable program code means for causing the computer to determine the angular orientation of the image sensor comprises:

computer readable program code means for causing the computer to determine the angular orientation of the image sensor based on an angular orientation data received from an angular orientation measuring element associated with the image sensor.

33. The computer program product of claim **32**, wherein said second computer readable program code means for causing the computer to determine the angular orientation of the image sensor further comprises:

computer readable program code means for causing the computer to receive the angular orientation data from at least one of an accelerometer, a magnetometer, or a gyroscope associated with the image sensor.

34. The computer program product of claim **31**, wherein said third computer readable program code means for causing the computer to calculate the plurality of respective distances from the image sensor to the plurality of point sources of light comprises:

computer readable program code means for causing the computer to calculate the plurality of respective dis-

tances based on the plurality of respective fixed and identified locations of the point sources in relation to the coordinate system.

35. The computer program product of claim **31**, wherein said third computer readable program code means for causing the computer to calculate the plurality of respective distances from the image sensor to the plurality of point sources of light comprises:

computer readable program code means for causing the computer to calculate the plurality of respective distances based on the angular orientation of the image sensor in relation to the coordinate system.

36. The computer program product of claim **31**, wherein said third computer readable program code means for causing the computer to calculate the plurality of respective distances from the image sensor to the plurality of point sources of light comprises:

(i) computer readable program code means for causing the computer to calculate the plurality of respective distances based on a plurality of respective angles of incidence at the image sensor of light from the plurality of point sources.

37. The computer program product of claim **36**, wherein said computer readable program code means for causing the computer to calculate the plurality of respective distances based on a plurality of respective angles of incidence at the image sensor of light from the plurality of point sources comprises:

(i)(a) computer readable program code means for causing the computer to receive from the image sensor a plurality of detected incidences of light from the plurality of point sources detected by the image sensor.

38. The computer program product of claim **37**, wherein a detected incidence of light comprises at least one of a location on an imaging element of the image sensor of a ray of light or an intensity at the imaging element of the ray of light; and

wherein said computer readable program code means for causing the computer to calculate the plurality of respective distances based on the plurality of respective angles of incidence at the image sensor of light from the plurality of point sources further comprises:

(i)(b) computer readable program code means for causing the computer to calculate the plurality of respective angles of incidence based on at least one of:

the location on the imaging element of the image sensor of the ray of light; or

the intensity at the imaging element of the ray of light.

39. The computer program product of claim **31**, wherein said third computer readable program code means for causing the computer to calculate the plurality of respective distances from the image sensor to the plurality of point sources of light further comprises:

computer readable program code means for causing the computer to calculate the plurality of respective distances based on a stereoscopic imaging data of the plurality of point sources by an image sensor configured as a stereoscopic image sensor.

40. The computer program product of claim **31**, wherein said fourth computer readable program code means for caus-

ing the computer to calculate the position of the image sensor based on the angular orientation and the plurality of respective distances comprises:

(i) computer readable program code means for causing the computer to determine equations which define a plurality of spheres, wherein:

each sphere of the plurality of spheres is centered around a coordinate location of a respective point source of light of the plurality of point sources; and

each sphere has a respective radius equal to the respective distances from the image sensor to the respective point sources of light.

41. The computer program product of claim **40**, wherein said fourth computer readable program code means for causing the computer to calculate the position of the image sensor based on the angular orientation and the plurality of respective distances further comprises:

(ii) computer readable program code means for causing the computer to calculate an intersection of the spheres, wherein the intersection comprises at least one of a circle, a set of points, or a point.

42. The computer program product of claim **41**, wherein said fourth computer readable program code means for causing the computer to calculate the position of the image sensor based on the angular orientation and the plurality of respective distances further comprises:

(iii) computer readable program code means for causing the computer to determine the position of the image sensor in relation to the coordinate system based on the point of intersection of the spheres.

43. The computer program product of claim **41**, wherein said fourth computer readable program code means for causing the computer to calculate the position of the image sensor based on the angular orientation and the plurality of respective distances further comprises:

(iii) computer readable program code means for causing the computer to calculate an equation of a line from the image sensor to a point source of light of the plurality of point sources.

44. The computer program product of claim **43**, wherein said computer readable program code means for causing the computer to calculate the equation of the line comprises:

(iv) computer readable program code means for causing the computer to calculate the equation of the line based on:

the respective fixed and identified location of the point source in relation to the coordinate system;

the angular orientation of the image sensor in relation to the coordinate system and

an angle of incidence of light from the point source of light at the image sensor.

45. The computer program product of claim **43**, wherein said fourth computer readable program code means for causing the computer to calculate the position of the image sensor based on the angular orientation and the plurality of respective distances further comprises:

(iv) computer readable program code means for causing the computer to calculate an intersection of the line with the intersection of the spheres.

* * * * *