



US 20080301016A1

(19) **United States**

(12) **Patent Application Publication**
Durvasula et al.

(10) **Pub. No.: US 2008/0301016 A1**
 (43) **Pub. Date: Dec. 4, 2008**

(54) **METHOD, SYSTEM, AND COMPUTER PROGRAM PRODUCT FOR CUSTOMER LINKING AND IDENTIFICATION CAPABILITY FOR INSTITUTIONS**

(22) Filed: **May 30, 2007**

Publication Classification

(75) Inventors: **Sastry Vsm Durvasula**, Phoenix, AZ (US); **Venkata Prathipati**, Scottsdale, AZ (US); **Sandeep Sacheti**, Edison, NJ (US); **Laxminarayana Somayaji**, Phoenix, AZ (US); **Frank J. Straka**, Phoenix, AZ (US); **Jessica Taizin Lu**, Scottsdale, AZ (US); **Mary Weissman**, Mesa, AZ (US)

(51) **Int. Cl.**
G06Q 40/00 (2006.01)
 (52) **U.S. Cl.** **705/35**

(57) **ABSTRACT**

In an enterprise where a database maintains multiple accounts for one or more business customers, a method, system, and computer program product correctly links accounts which are associated with a single location of a common business. Further hierarchical linkages are established between accounts associated with multiple locations of the common business. The linkages are established via matching rules, the matching rules including provisions for optimizing the quality of the account data, integrating account-related data from external sources, and assigning quality-of-matching factors to different kinds of account data. Both internal and external account data are utilized to create an integrated view, or "business demographics", of the business structure of the single common business shared by the linked, hierarchically-related accounts. Separate accounts of separate businesses which are nonetheless related accounts may be associated with each other. Feedback loops may be used to correct both erroneous data and the linking rules.

Correspondence Address:
STERNE, KESSLER, GOLDSTEIN & FOX, P.L. L.C.
 1100 NEW YORK AVENUE, N.W.
 WASHINGTON, DC 20005-3934 (US)

(73) Assignee: **American Express Travel Related Services Company, Inc. General Counsel's Office**, New York, NY (US)

(21) Appl. No.: **11/755,313**

100

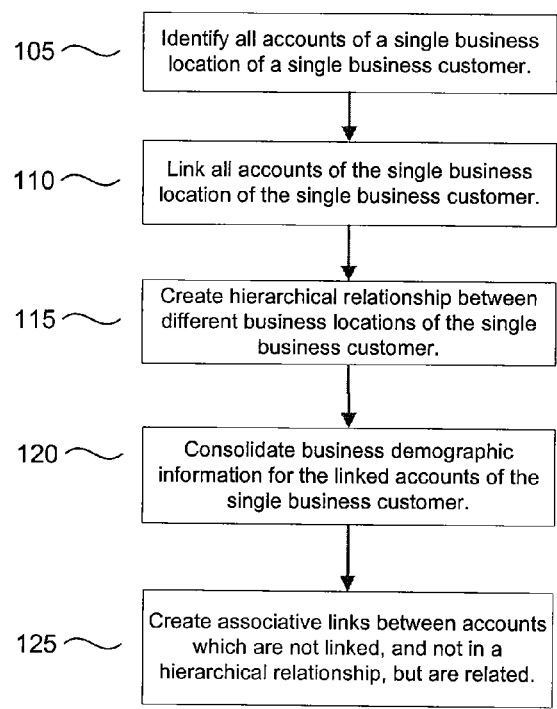

[0039] Step 105 entails identifying a plurality of accounts of a single business customer at a single location of the single business customer. For example one, or more account databases of the enterprise may be searched to identify business records which are associated with the single business location.

[0040] In step 110 the plurality of accounts which have been identified in step 105 as being associated with a single business location of a single business customer may be linked to each other. The linkage is accomplished, for example, by assigning to such accounts a shared or common identification value. This identification value may be unique within the database to these linked accounts, and may be a persistent ID value in the sense that in the normal course of operations it will not typically be changed over time. The exact nature of this unique, persistent ID value, which may be a number, an alphanumeric designation, or some similar identifier, may vary according to different embodiments of the present invention.

[0041] Steps 105 and 110 may be repeated for each unique location of each business customer within the enterprise database, such that for each unique location of each business customer, a plurality of the business accounts associated with a particular business location of a given particular business customer may be linked to each other. The result is an enterprise database which, for a plurality of business customers in the database, correctly reflects and indicates a plurality of the accounts that are associated with each unique location for each customer of the plurality of business customers.

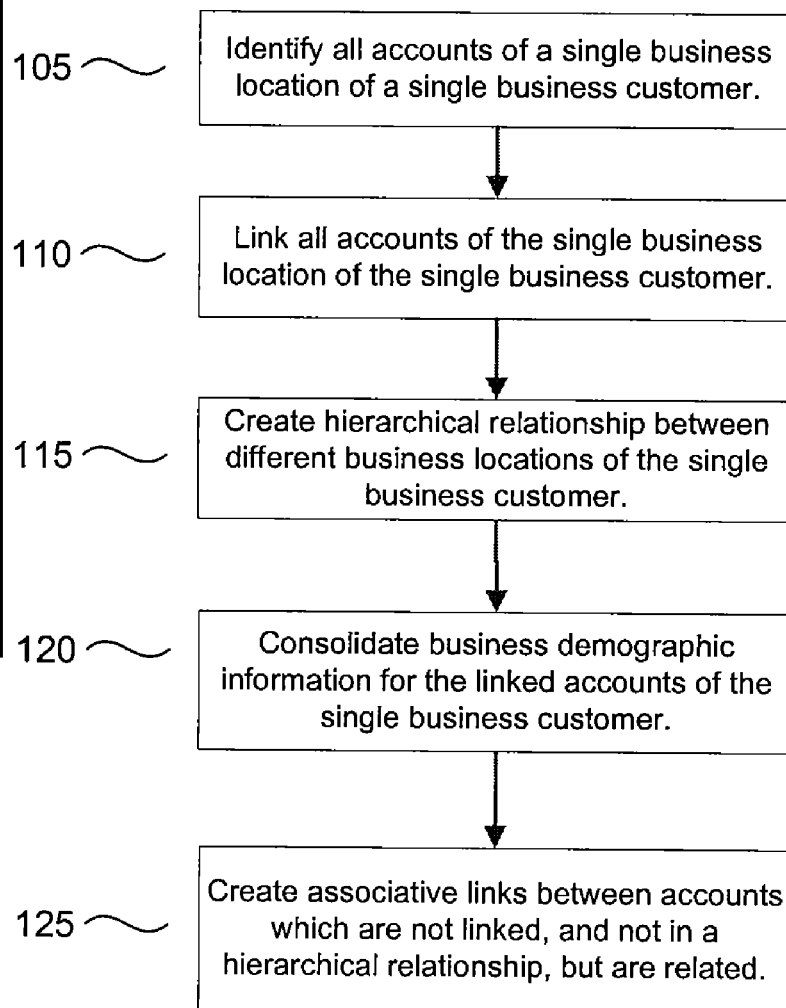

[0042] Step 115 entails creating a hierarchical relationship between different business locations of the single business customer. As with steps 105 and 110, step 115 is repeated for each business customer of the enterprise. As a result, the database comes to include not just a database of separate accounts, but instead a database where a plurality of accounts for each business may be linked to each other, either directly linked through a shared common identifier if the accounts are accounts of a single location, or accounts linked in a hierarchical relationship which reflects the business structure for each business.

[0043] The preceding steps entail gathering business information for each account within the database. The information gathered includes, for example and without limitation, information on employees of the business, sales information, various incorporation and other legal information pertaining to the business, business ownership, and numerous other elements of information pertaining to the operations and structure of the business. Such information is collectively referred to as "business demographics" (again, sometimes referred to in the art as "firmographics").

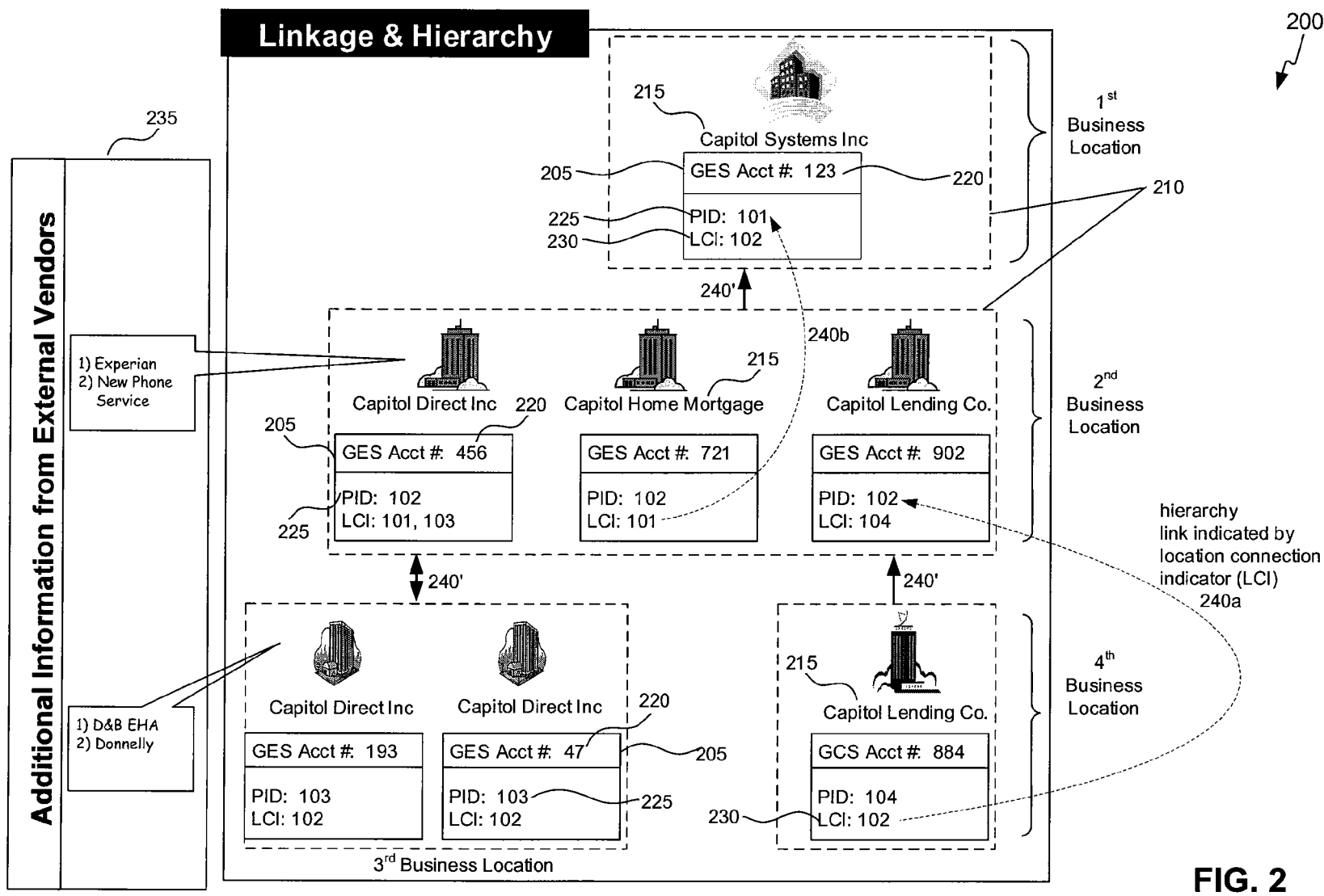

FIG. 2

[0046] FIG. 2 illustrates exemplary linkage and hierarchy relationships established between accounts for a single business in accordance with steps 105, 110, and 115 of exemplary method 100. Illustrated are multiple accounts 205 associated with various business locations 210 of a single business.....

[0047] As a result of, for example, method 100, a plurality of accounts of a common location are assigned a common, unique, persistent ID (PID), here illustrated as exemplary persistent IDs (PIDs) 225. In addition, different locations within the common business may be linked to each other in a hierarchical fashion....

I-CLIC Hierarchy

300

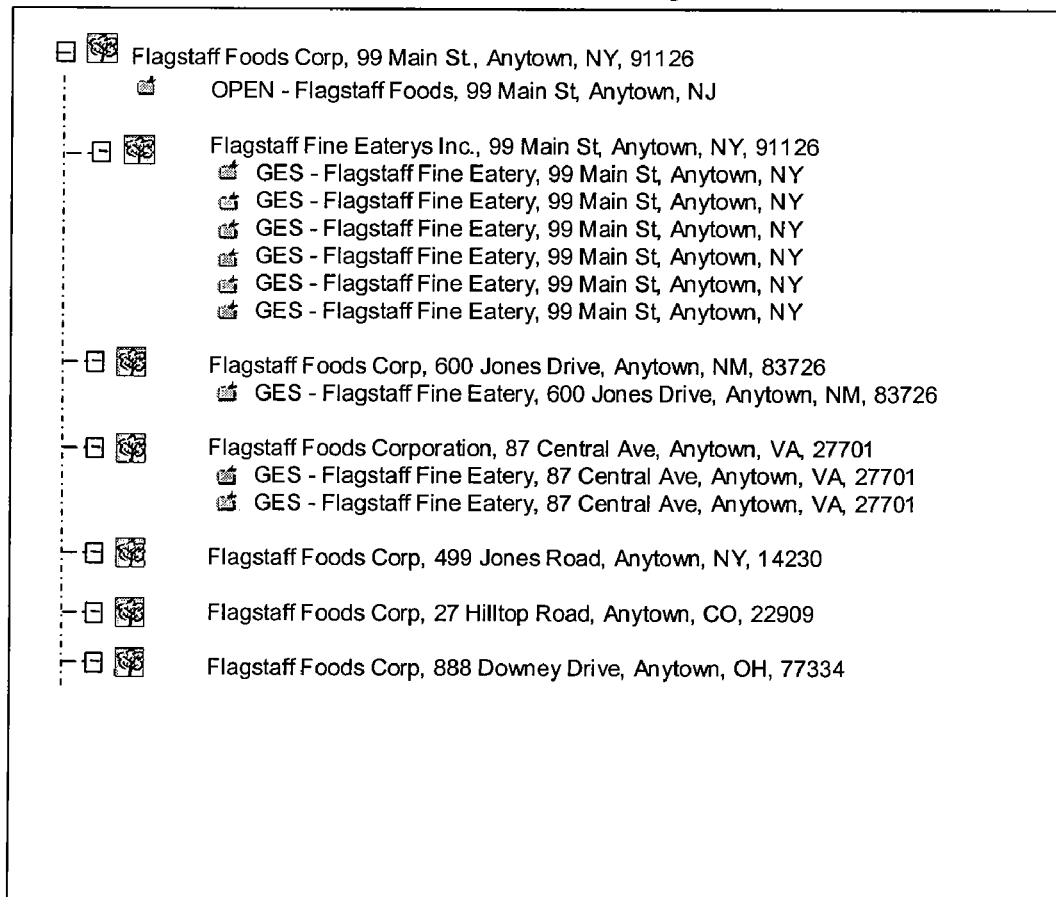

Key Insights

320

Total Business at Locations (B@L)	109
Total AXP Relationships: (GCS: 0, GES: 80, OPEN:22)	102
B@L with AXP relationships	65
B@L with no AXP Relationships	44
AXP Penetration	60%
B@L with multiple BU relationships	10

Key Business Demographics

310

Global Ultimate Name	Flagstaff Foods Corp
Address	99 Main St, Anytown, NY, 07649
Location Head	J J Smith
Business Start Year	1986
Employees Total	1,000 (actual)
D&B Revenue	\$ 33,900,000 (estimated)
Industry	Food Services
Legal Status	Corporation
Marketability Indicator	Yes
Out of Business	No
Tax ID	*****2790

FIG. 3

[0081] FIG. 3 illustrates an exemplary iCLIC hierarchy 300 for a particular business, Flagstaff Foods Corporation. Associated with the hierarchy are general business demographics 310 (labeled as "Key Business Demographics") for the business as a whole. However, in addition to simply consolidating the data, an insight-oriented assessment of the business data is enabled, as shown under the heading "Key Insights" 320.

[0093] FIG. 4 illustrates an exemplary associative linking 400 of two accounts according to an embodiment of the present invention. First account 405 is a merchant account of a first business, Acme Engineering Company, while second account 410 is a credit card account of a second company Jan's Beauty Shop. The two businesses are not associated, and do not share any significant information suggesting a linkage between the two accounts, other than the fact that the account contact names share a last name "Smith" (Paul Smith 415 and Janice Smith 420). {continued below}

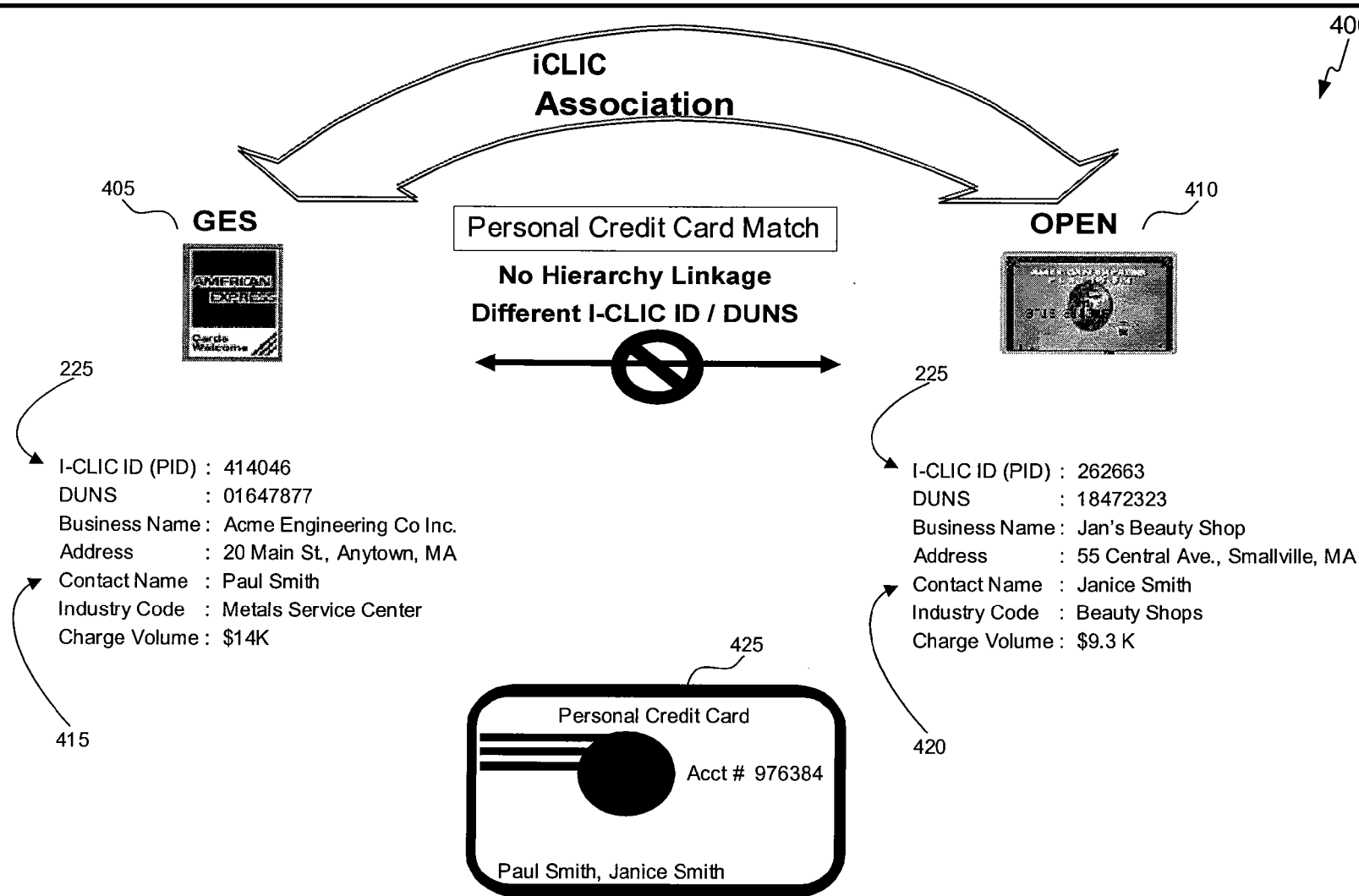

FIG. 4

[0093 (continued)] However, an analysis of personal credit card record 425, which is maintained by the same enterprise which maintains the two business accounts 405, 410, reveals that Paul Smith 415 and Janice Smith 420 share common ownership of credit card 425. (Further account data may indicate that Paul Smith 415 and Janice Smith 420 are married or share some other relationship viewed as a basis for associative linking.) Based on the associative linking rules, an associative link is then established...

[0122]In one embodiment, the invention is directed toward one or more computer systems capable of carrying out the functionality described herein. An example of a computer system 500 is shown in FIG. 5.

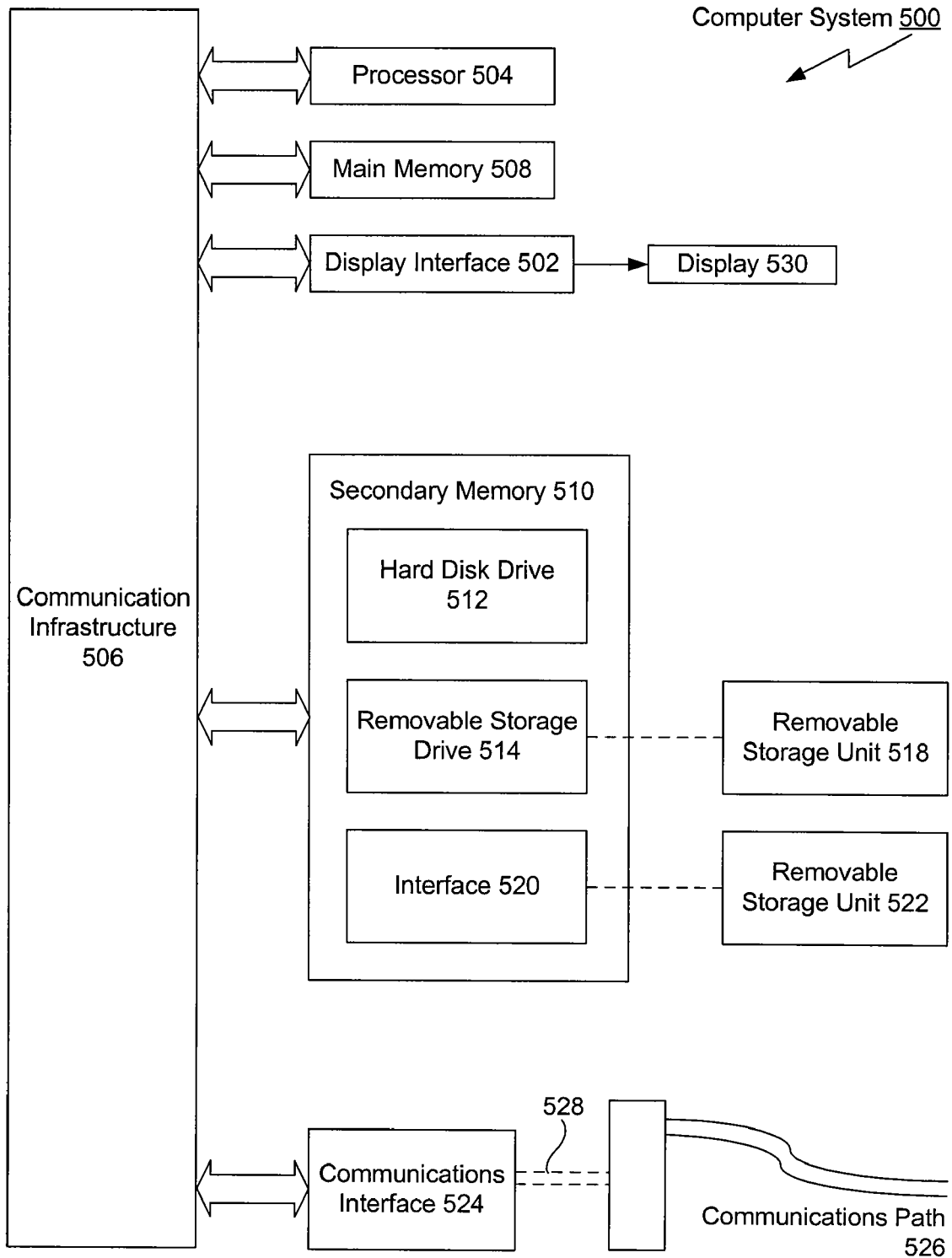

FIG. 5

**METHOD, SYSTEM, AND COMPUTER
PROGRAM PRODUCT FOR CUSTOMER
LINKING AND IDENTIFICATION
CAPABILITY FOR INSTITUTIONS**

BACKGROUND OF THE INVENTION

[0001] 1. Field of the Invention

[0002] The present invention generally relates to managing business customer information, and more particularly to linking business customer accounts within a database.

[0003] 2. Related Art

[0004] Businesses and other institutional clients often have more than one account established through a particular enterprise, especially with a service-oriented enterprise such as a financial services enterprise or an insurance enterprise. In the case of an enterprise of the financial services industry, for example, a single business customer may have any combination of one or more bank accounts, lines of credit, business credit cards, and investment accounts with the single financial enterprise. For an enterprise in the insurance business, a single business customer of the enterprise may have any combination of health insurance, property insurance, liability insurance, and other kinds of insurance protection as well.

[0005] In some cases, the enterprise database may reflect that different accounts may be associated with different names or entities of the same business, even if these various entities share a common address. In still other cases, various accounts in the enterprise database may be listed with variations of the same address. Some different accounts of the same business may even use post office box addresses or other alternate addresses rather than direct mailing addresses, all to describe what is actually a single physical location of the business.

[0006] In addition, a single business may operate out of multiple business locations, typically though not necessarily with one location being a main headquarters, while other locations function in various subsidiary capacities.

[0007] As a result, during the process of contacting a business for marketing or other purposes, an enterprise may make redundant contacts, e.g., distributing marketing literature to multiple locations of the same business. If the same business location is listed in an enterprise database with two variations on the same address, or two variations on the same contact name, the same location or contact person may even be contacted twice by the enterprise. Equally problematic, an enterprise may contact these multiple channels of the same business with different or inconsistent information, such as different marketing offers related to the same product. These multiple contacts increase the cost for an enterprise of marketing to or otherwise contacting businesses, and further result in inconsistent contact approaches.

[0008] Further, a business may express preferences about how it is to be contacted. However, if the different locations or executives of the business are not recognized as actually belonging to the common business, these preferences may not be consistently respected by the enterprise as the enterprise contacts different locations, business units, or staff within the business.

[0009] Still further, when an enterprise seeks to market additional services or provide customer support services to a particular, existing business customer, the enterprise benefits from having an integrated, holistic view of the business structure and business operations of that particular business customer. Yet when various accounts of a single business cus-

tomers are erroneously seen—from the perspective of an enterprise database—as separate accounts of separate customers, it is difficult or impossible for the enterprise to achieve the desired integration of business information across all accounts of the given, single business customer. This impedes the ability to provide the desired quality of marketing and support directed towards any given, particular business customer.

[0010] Given the foregoing, what is needed then is a system, method, and computer program product for ensuring that multiple account listings maintained by an enterprise for a common business or common institution are linked together, so that consistent contact, marketing, support, and related policies may be established and implemented, so that business customer preferences may be respected in most or all contacts with the business, and so that a consistent and complete picture of the business customer may be maintained across most or all accounts of the business customer.

BRIEF SUMMARY OF THE INVENTION

[0011] A method, system, and computer program product for linking customer information for businesses or other institutions is provided. This is referred to as the customer linking and identification capability for institutions (iCLIC).

[0012] In one embodiment of the invention, business account data from a plurality of internal and external data sources is collected. An analysis is performed using a plurality of matching rules to determine which accounts are actually accounts of the same business or institution. Linkages are then created between a plurality of accounts associated with a single, particular location of a single business or institution, by assigning a common, unique, persistent ID shared by the plurality of such accounts of the business/institution.

[0013] Further processing may establish a series of hierarchical linkages between different locations of the business and therefore, implicitly or explicitly, between accounts associated with different locations of the business.

[0014] Detailed information about the business, which may include earnings and other financial statistics, names of key executives, product lines, and similar data, may be collected and consolidated across a plurality of business units at a plurality of locations of the single business. This consolidated data is collectively referred to as “business demographics” (sometimes referred to in the art as “firmographics”), and delivers to the enterprise a consistent picture of the business for marketing, customer support, and related purposes.

[0015] Another kind of linkage, referred to as an “association”, may be established between accounts which may actually belong to separate businesses or institutions, but which are nonetheless related in some way. These associations between accounts provide further insight into a business for marketing, customer support, and related purposes.

[0016] Further embodiments, features, and advantages of the present invention, as well as the structure and operation of the various embodiments of the present invention, are described in detail below with reference to the accompanying drawings.

**BRIEF DESCRIPTION OF THE
DRAWINGS/FIGURES**

[0017] The features and advantages of the present invention will become more apparent from the detailed description set forth below when taken in conjunction with the drawings in

the features of the present invention, as discussed herein. In particular, the computer programs, when executed, enable the processor 504 to perform the features of the present invention. Accordingly, such computer programs represent controllers of the computer system 500.

[0130] In an embodiment where the invention is implemented using software, the software may be stored in a computer program product and loaded into computer system 500 using removable storage drive 514, hard drive 512 or communications interface 524. The control logic (software), when executed by the processor 504, causes the processor 504 to perform the functions of the invention as described herein.

[0131] In another embodiment, the invention is implemented primarily in hardware using, for example, hardware components such as application specific integrated circuits (ASICs). Implementation of the hardware state machine so as to perform the functions described herein will be apparent to persons skilled in the relevant art(s).

[0132] In yet another embodiment, the invention is implemented using a combination of both hardware and software.

VI. CONCLUSION

[0133] While various embodiments of the present invention have been described above, it should be understood that they have been presented by way of example, and not limitation. It will be apparent to persons skilled in the relevant art(s) that various changes in form and detail can be made therein without departing from the spirit and scope of the present invention. Thus, the present invention should not be limited by any of the above described exemplary embodiments, but should be defined only in accordance with the following claims and their equivalents.

[0134] In addition, it should be understood that the figures and screen shots illustrated in the attachments, which highlight the functionality and advantages of the present invention, are presented for example purposes only. The architecture of the present invention is sufficiently flexible and configurable, such that it may be utilized (and navigated) in ways other than that shown in the accompanying figures.

[0135] Further, the purpose of the foregoing Abstract is to enable the U.S. Patent and Trademark Office and the public generally, and especially the scientists, engineers and practitioners in the art who are not familiar with patent or legal terms or phraseology, to determine quickly from a cursory inspection the nature and essence of the technical disclosure of the application. The Abstract is not intended to be limiting as to the scope of the present invention in any way.

1. A method of managing accounts stored by an enterprise, wherein said accounts are accounts of at least one business customer of a plurality of business customers of the enterprise, comprising:

identifying a plurality of accounts associated with a single location of the at least one business customer;

linking the plurality of accounts associated with the single location;

repeating said identifying and linking steps for a plurality of single locations of the at least one business customer, wherein a first identification and linkage is made to link a plurality of accounts of a first location of the at least one business customer and a second identification and linkage is made to link a plurality of accounts of a second location of the at least one business customer;

creating a hierarchical relationship between at least an account of the first location and at least an account of the second location; and

capturing business demographics for the linked accounts of the at least one business customer.

2. The method of claim 1, further comprising:

identifying a first account of the plurality of business customers of the enterprise and a second account of the plurality of business customers of the enterprise;

determining that the first account is not linked to the second account;

determining that the first account is not in a hierarchical relationship with the second account;

determining according to a plurality of association rules that an association exists between the first account and the second account; and

creating an associative link between the first account and the second account.

3. The method of claim 2, wherein determining according to a plurality of association rules that an association exists between the first account and the second account comprises at least one of:

determining that the first account and the second account are accounts of a common person;

determining that the first account and the second account are accounts sharing a common business interest;

determining that the first account and the second account are accounts sharing a common demographic;

determining that the first account and the second account are accounts of a respective first business and second business wherein the first business and the second business are at least one of commonly owned businesses or associated businesses;

determining that the first account and the second account are accounts of a respective first business unit and a respective second business unit of a common business, where a rule exists to not link accounts between the first business unit and the second business unit; and

determining that the first account and the second account are accounts of a respective first person and second person wherein the first person is associated with the second person through at least one of a common business dealing, a common business association, or a common personal association.

4. The method of claim 1, wherein linking the plurality of accounts associated with the single location comprises:

applying a plurality of matching rules to a plurality of account data, wherein a first account of the plurality of accounts of the single location is matched to a second account of the plurality of accounts of the single location; and

linking the first account with the second account by assigning a common identification value to the first account and the second account.

5. The method of claim 4, wherein applying the plurality of matching rules to the plurality of account data comprises at least one of:

comparing a plurality of account identification attributes of the plurality of account data according to a plurality of comparison rules to determine a probability of a match between the first account and the second account;

customizing the plurality of comparison rules by assigning a quality-of-match level for at least one account identification attribute of the plurality of account identification attributes;

analyzing at least one of a business data obtained from a secondary data source and personal data obtained from the secondary data source;

removing extraneous identifying information from the plurality of account data; standardizing the data format of the plurality of account data;

including multiple addresses per account;

updating the plurality of account data based on merger, acquisition, and divestiture data;

obtaining business data from an external data source;

obtaining business data for a prospective customer;

making multiple passes through the account data to maximize a match rate; and

selectively applying matching rules in accordance with at least one of a type of the account and a type of a business unit of the at least one business customer.

6. (canceled)

7. The method of claim 1, further comprising:

applying a data feedback loop to identify a data anomaly, wherein the data anomaly comprises at least one of a proprietary linkage, a questionable linkage, a questionable hierarchy, a questionable data quality of external data, a questionable data quality of internal data, and a data inconsistency;

determining a source of the data anomaly, wherein the source of the data anomaly comprises at least one of an effectiveness of a linking rule, a requirement for the linking rule, a misapplication of the linking rule, an effectiveness of a hierarchy rule, a requirement for the hierarchy rule, a misapplication of the hierarchy rule, a data error in an external data source, and a data error in an internal data source; and

rectifying the source of the data anomaly by at least one of adding the linking rule, modifying the linking rule, deleting the linking rule, adding the hierarchy rule, modifying the hierarchy rule, deleting the hierarchy rule, changing the application of the linking rule, changing the application of the hierarchy rule, changing a parameter of the linking rule, changing a parameter of the hierarchy rule, correcting an error in the external data, and correcting an error in the internal data.

8. (canceled)

9. The method of claim 7, further comprising generating a report indicative of at least one of a data input, a data input quality, a data output, a data output quality, a result of an application of the linking rule, and a result of an application of the hierarchy rule.

10. The method of claim 1, wherein creating the hierarchical relationship between at least the account of the first location and at least the account of the second location comprises at least one of:

creating a hierarchical relationship based on an organizational structure of the at least one business customer; and
creating a hierarchical relationship based on a financial transaction of the accounts of the at least one business customer with a common financial structure.

11. The method of claim 1, wherein creating the hierarchical relationship between at least the account of the first location and at least the account of the second location comprises:

creating a first set of hierarchical account relationships based on a first hierarchical criteria;

creating a second set of hierarchical account relationships based on a second hierarchical criteria, wherein the second hierarchical criteria is different from the first hierarchical criteria;

comparing the first set of hierarchical account relationships with the second set of hierarchical account relationships to detect an inconsistency between the first set and the second set; and

detecting at least one of an erroneous business data, an erroneous linking rule, and an erroneous hierarchy rule based on the inconsistency between the first set and the second set.

12. The method of claim 1, wherein capturing business demographics for the linked accounts of the at least one business customer comprises:

capturing at least one of demographic information, number of years in business, an industry code, an industry code with an extension, an executive, a business revenue, and an employee count of the at least one business customer; and

refreshing the at least one of demographic information, number of years in business, the industry code, the industry code with an extension, the executive, the business revenue, and the employee count periodically to track at least one of a growth of the business and a deterioration of the business.

13. A system for managing accounts stored by an enterprise, wherein said accounts are accounts of at least one business customer of a plurality of business customers of the enterprise, comprising:

a processor; and

a memory in communication with the processor, the memory storing a plurality of processing instructions for directing the processor to:

(a) identify a plurality of accounts associated with a single location of the at least one business customer;

(b) link the plurality of accounts associated with the single location;

(c) repeat steps (a) and (b) for a plurality of single locations of the at least one business customer, wherein a first identification and linkage is made to link a plurality of accounts of a first location of the at least one business customer and a second identification and linkage is made to link a plurality of accounts of a second location of the at least one business customer;

(d) create a hierarchical relationship between at least an account of the first location and at least an account of the second location; and

(e) capture business demographics for the linked accounts of the at least one business customer.

14. The system of claim 13, further comprising instructions for directing the processor to:

(f) identify a first account of the plurality of business customers of the enterprise and a second account of the plurality of business customers of the enterprise;

(g) determine that the first account is not linked to the second account;

(h) determine that the first account is not in a hierarchical relationship with the second account;

(i) determine according to a plurality of association rules that an association exists between the first account and the second account; and

- (j) create an associative link between the first account and the second account.

15. The system of claim **14**, wherein the instructions for directing the processor to determine according to a plurality of association rules that an association exists between the first account and the second account comprise at least one of instructions for directing the processor to:

- (k) determine that the first account and the second account are accounts of a common person;
- (l) determine that the first account and the second account are accounts sharing a common business interest;
- (m) determine that the first account and the second account are accounts sharing a common demographic;
- (n) determine that the first account and the second account are accounts of a respective first business and second business wherein the first business and the second business are at least one of commonly owned businesses or associated businesses;
- (o) determine that the first account and the second account are accounts of a respective first business unit and a respective second business unit of a common business, where a rule exists to not link accounts between the first business unit and the second business unit; and
- (p) determine that the first account and the second account are accounts of a respective first person and second person wherein the first person is associated with the second person through at least one of a common business dealing, a common business association, or a common personal association.

16. The system of claim **13**, wherein the instructions for directing the processor to link the plurality of accounts associated with the single location comprise instructions for directing the processor to:

- (f) apply a plurality of matching rules to a plurality of account data, wherein a first account of the plurality of accounts of the single location is matched to a second account of the plurality of accounts of the single location; and
- (g) link the first account with the second account by assigning a common identification value to the first account and the second account.

17. The system of claim **16**, wherein the instructions for directing the processor to apply the plurality of matching rules to the plurality of account data comprise at least one of instructions for directing the processor to:

- (h) compare a plurality of account identification attributes of the plurality of account data according to a plurality of comparison rules to determine a probability of a match between the first account and the second account;
- (i) customize the plurality of comparison rules by assigning a quality-of-match level for at least one account identification attribute of the plurality of account identification attributes;
- (j) analyze at least one of a business data obtained from a secondary data source and a personal data obtained from the secondary data source;
- (k) remove extraneous identifying information from the plurality of account data;
- (l) standardize the data format of the plurality of account data;
- (m) include multiple addresses per account;
- (n) update the plurality of account data based on merger, acquisition, and divestiture data;
- (o) obtain business data from an external data source;

- (p) obtain business data for a prospective customer;
- (q) make multiple passes through the account data to maximize a match rate; and
- (r) selectively apply the matching rules in accordance with at least one of a type of the account and a type of a business unit of the at least one business customer.

18. (canceled)

19. The system of claim **13**, further comprising instructions for directing the processor to:

- (f) apply a data feedback loop to identify a data anomaly, wherein the data anomaly comprises at least one of a proprietary linkage, a questionable linkage, a questionable hierarchy, a questionable data quality of external data, a questionable data quality of internal data, and a data inconsistency;
- (g) determine a source of the data anomaly, wherein the source of the data anomaly comprises at least one of an effectiveness of a linking rule, a requirement for the linking rule, a misapplication of the linking rule, an effectiveness of a hierarchy rule, a requirement for the hierarchy rule, a misapplication of the hierarchy rule, a data error in an external data source, and a data error in an internal data source; and
- (h) rectify the source of the data anomaly by at least by at least one of adding the linking rule, modifying the linking rule, deleting the linking rule, adding the hierarchy rule, modifying the hierarchy rule, deleting the hierarchy rule, changing the application of the linking rule, changing the application of the hierarchy rule, changing a parameter of the linking rule, changing a parameter of the hierarchy rule, correcting an error in the external data, and correcting an error in the internal data.

20. (canceled)

21. (canceled)

22. The system of claim **13**, wherein the instructions of step (d) for directing the processor to create the hierarchical relationship between at least the account of the first location and at least the account of the second location comprise at least one of:

- (f) instructions for directing the processor to create a hierarchical relationship based on an organizational structure of the at least one business customer; and
- (g) instructions for directing the processor to create a hierarchical relationship based on a financial transaction of the accounts of the at least one business customer with a common financial structure.

23. The system of claim **13**, wherein the instructions of step (d) for directing the processor to create the hierarchical relationship between at least the account of the first location and at least the account of the second location comprise instructions for directing the processor to:

- (f) create a first set of hierarchical account relationships based on a first hierarchical criteria;
- (g) create a second set of hierarchical account relationships based on a second hierarchical criteria, wherein the second hierarchical criteria is different from the first hierarchical criteria;
- (h) compare the first set of hierarchical account relationships with the second set of hierarchical account relationships to detect an inconsistency between the first set and the second set; and

- (i) detect at least one of an erroneous business data, an erroneous linking rule, and an erroneous hierarchy rule based on the inconsistency between the first set and the second set.

24. The system of claim **13**, wherein the instructions for directing the processor to capture business demographics for the linked accounts of the at least one business customer comprise:

- (f) instructions for directing the processor to capture at least one of demographic information, number of years in business, an industry code, an industry code with an extension, a highest ranking official, a business revenue, and an employee count of the at least one business customer; and
- (g) instructions for directing the processor to refresh the at least one of demographic information, number of years in business, the industry code, the industry code with an extension, the executive, the business revenue, and the employee count periodically to track at least one of a growth of the business and a deterioration of the business.

25. A computer program product comprising a computer usable medium having control logic stored therein for causing a computer to manage accounts stored by an enterprise, wherein said accounts are accounts of at least one business customer of a plurality of business customers of the enterprise, said control logic comprising:

first computer readable program code means for causing the computer to identify a plurality of accounts associated with a single location of the at least one business customer;

second computer readable program code means for causing the computer to link the plurality of accounts associated with the single location;

third computer readable program code means for causing the computer to repeat said identifying and linking steps for a plurality of single locations of the at least one business customer, wherein a first identification and linkage is made to link a plurality of accounts of a first location of the at least one business customer and a second identification and linkage is made to link a plurality of accounts of a second location of the at least one business customer;

fourth computer readable program code means for causing the computer to create a hierarchical relationship between at least an account of the first location and at least the account of a second location;

fifth computer readable program code means for causing the computer to capture business demographics for the linked accounts of the at least one business customer; and

sixth computer readable program code means for causing the computer to determine for a first account which is not linked to a second account and which is not in a hierarchical relationship with the second account that an association exists between the first account and the second account, and for causing the computer to create an associative link between the first account and the second account.

26. The computer program product of claim **25**, wherein said second computer readable program code means comprises:

seventh computer readable program code means for causing the computer to apply a plurality of matching rules to

a plurality of account data, wherein a first account of the plurality of accounts of the single location is matched to a second account of the plurality of accounts of the single location; and

eighth computer readable program code means for causing the computer to link the first account with the second account by assigning a common identification value to the first account and the second account.

27. The computer program product of claim **26**, wherein said seventh computer readable program code means comprises at least one of:

ninth computer readable program code means for causing the computer to compare a plurality of account identification attributes of the plurality of account data according to a plurality of comparison rules to determine a probability of a match between the first account and the second account;

tenth computer readable program code means for causing the computer to customize the plurality of comparison rules by assigning a quality-of-match level for at least one account identification attribute of the plurality of account identification attributes;

eleventh computer readable program code means for causing the computer to analyze at least one of a business data obtained from a secondary data source and a personal data obtained from the secondary data source;

twelfth computer readable program code means for causing the computer to remove extraneous identifying information from the plurality of account data;

thirteenth computer readable program code means for causing the computer to standardize the data format of the plurality of account data;

fourteenth computer readable program code means for causing the computer to include multiple addresses per account;

fifteenth computer readable program code means for causing the computer to update the plurality of account data based on merger, acquisition, and divestiture data;

sixteenth computer readable program code means for causing the computer to obtain business data from an external data source;

seventeenth computer readable program code means for causing the computer to obtain business data for a prospective customer; and

and eighteenth computer readable program code means for causing the computer to make multiple passes through the account data to maximize a match rate.

28. The computer program product of claim **26**, further comprising:

ninth computer readable program code means for causing the computer to apply a data feedback loop to identify a data anomaly, wherein the data anomaly comprises at least one of a proprietary linkage, a questionable linkage, a questionable hierarchy, a questionable data quality of external data, a questionable data quality of internal data, and a data inconsistency;

tenth computer readable program code means for causing the computer to determine a source of the data anomaly, wherein the source of the data anomaly comprises at least one of an effectiveness of a linking rule, a requirement for the linking rule, a misapplication of the linking rule, an effectiveness of a hierarchy rule, a requirement for the hierarchy rule, a misapplication of the hierarchy

rule, a data error in an external data source, and a data error in an internal data source; and

eleventh computer readable program code means for causing the computer to rectify the source of the data anomaly by at least by at least one of adding the linking rule, modifying the linking rule, deleting the linking rule, adding the hierarchy rule, modifying the hierarchy rule, deleting the hierarchy rule, changing the application of the linking rule, changing the application of the hierarchy rule, changing a parameter of the linking rule, changing a parameter of the hierarchy rule, correcting an error in the external data, and correcting an error in the internal data.

29. The computer program product of claim 28, wherein the ninth computer readable program code means for causing the computer to apply the data feedback loop to identify the data anomaly comprises at least one of:

twelfth computer readable program code means for causing the computer to apply an automated data auditing rule to a linking process output;

thirteenth computer readable program code means for causing the computer to present a user-interface means for a human operator to audit the linking process; and

fourteenth computer readable program code means for causing the computer to generate a report indicative of at least one of a data input, a data input quality, a data output, a data output quality, a result of an application of the linking rule, and a result of an application of the hierarchy rule.

30. The computer program product of claim 25, wherein said fourth computer readable program code means for causing the computer to create the hierarchical relationship between at least the account of the first location of the at least

one business customer and at least the account of the second location of the at least one business customer comprises:

seventh computer readable program code means for instructing the processor to create a first set of hierarchical account relationships based on a first hierarchical criteria, wherein the first hierarchical criteria comprises at least one of:

an organizational structure of the at least one business customer; and

a financial transaction of the accounts of the at least one business customer with a common financial structure;

eighth computer readable program code means for instructing the processor to create a second set of hierarchical account relationships based on a second hierarchical criteria, wherein the second hierarchical criteria is different from the first hierarchical criteria and wherein the second hierarchical criteria comprises at least one of:

an organizational structure of the at least one business customer; and

a financial transaction of the accounts of the at least one business customer with a common financial structure;

ninth computer readable program code means for instructing the processor to compare the first set of hierarchical account relationships with the second set of hierarchical account relationships to detect an inconsistency between the first set and the second set; and

tenth computer readable program code means for instructing the processor to detect at least one of an erroneous business data, an erroneous linking rule, and an erroneous hierarchy rule based on the inconsistency between the first set and the second set.

* * * * *